

Field Manual  
No. 3-50

Headquarters  
Department of the Army  
Washington, DC, 4 December 1990

## **S m o k e   O p e r a t i o n s**

**DISTRIBUTION RESTRICTION:** Distribution is authorized to US government agencies only, to protect technical or operational information from automatic dissemination under the International Exchange Program or by other means. This determination was made 25 April 1990. Other requests for this document will be forwarded to Commandant, US Army Chemical School, ATTN: ATZN-CM-NF, Fort McClellan, AL 36205-5020.

**DESTRUCTION NOTICE:** Destroy by any method that will prevent disclosure of contents or reconstruction of the document.

\* This publication supersedes FM 3-50, 25 July 1984.

Change  
No. 1

Headquarters  
Department of the Army  
Washington, DC, 11 September 1996

## Smoke Operations

1. Change FM 3-50, 4 December 1990, as follows:

Remove old pages:	Insert new pages (attached)
3 through 4	3 through 4
97 through 98	97 through 98
	54-A through 54-D

2. New or changed material is indicated by a **█**

3. File this transmittal sheet in front of the publication.

**DISTRIBUTION RESTRICTION:** Distribution is authorized to US government agencies only, to protect technical or operational information from automatic dissemination under the International Exchange Program or by other means. This determination was made 25 April 1990. Other requests for this document will be forwarded to Commandant, US Army Chemical School, ATZN-CMR-A, Fort McClellan, AL 36205-5020.

**DESTRUCTION NOTICE:** Destroy by any method that will prevent disclosure of contents or reconstruction of the document.

By Order of the Secretary of the Army:

Official:



JOEL B. HUDSON

Administrative Assistant to the  
Secretary of the Army  
02289

DENNIS J. REIMER  
General, United States Army  
Chief of Staff

### DISTRIBUTION:

**Active Army, Army National Guard, and U.S. Army Reserve: To be distributed in accordance with the initial distribution number 110743, requirements for FM 3-50.**

# Contents

<b>Preface</b>	<b>2</b>		
<b>Chapter 1. Introduction</b>	<b>5</b>		
Historical Perspective	5		
Description of Smoke and Obscurants	6		
Uses of Smoke and Obscurants	6		
How and Where To Use Smoke	6		
Categories of Smoke Operations	7		
Smoke Planning	7		
Operational Concept for Smoke and Obscurants	9		
Operational Continuum	10		
Spectrum of Conflict	11		
The Battlefield	11		
Battlefield Applications of Smoke	13		
Smoke Delivery Means	14		
Smoke Units	15		
<b>Chapter 2. Threat</b>	<b>18</b>		
Reconnaissance, Surveillance, and Target Acquisition	18		
Combined Arms Operations	20		
Threat Smoke Tactics, Techniques, and Procedures	20		
Threat Offensive Smoke Use	21		
Threat Defensive Smoke Use	22		
Commander's Considerations	23		
US Countermeasures to Threat Use of Smoke	25		
<b>Chapter 3. Offensive Operations</b>	<b>27</b>		
Historical Perspective	27		
Tactics	28		
<b>Chapter 4. Defensive Operations</b>	<b>36</b>		
Historical Perspective	36		
Tactics	37		
		Elements of Defense	38
		<b>Chapter 5. Other Tactical Operations</b>	<b>42</b>
		Tactics	42
		Retrograde	42
		Relief in Place	43
		Passage of Lines	44
		Linkup Operations	44
		Breakout from Encirclement	45
		River Crossings	45
		Obstacle Breaching	46
		Special Conditions or Environments	46
		Deception	50
		<b>Chapter 6. Sustainment Planning</b>	<b>51</b>
		Maintenance, Supplies, and Logistics	52
		Fire Support and Security	53
		Personnel Sustainment	53
		<b>Chapter 7. Visual-Infrared Obscurants</b>	<b>54-A</b>
		<b>Appendix A Smoke Planning</b>	<b>55</b>
		Target Analysis Procedures	55
		Planning Documents	55
		Employment Matrixes	56
		<b>Appendix B. Electro-Optical Systems</b>	<b>72</b>
		Sensors and Effects	72
		Directed-Energy Weapons	76
		<b>Appendix C. Means of Delivery</b>	<b>78</b>
		Artillery Munitions	78
		Mortar Munitions	78
		Rockets	79
		Aircraft-Delivered Smoke	79
		Rifle Grenades	79
		Smoke Pots and Smoke Hand Grenades	80
		Generators	80

# FM 3-50, CI

Armored Vehicle Grenade Launchers 81	Ammunition Consumption Tables 88
Vehicle Engine Exhaust System 81	<b>Appendix F. Weather and Terrain 89</b>
Safety 82	Weather 89
<b>Appendix D. US Smoke Organizations and Capabilities 83</b>	Terrain Effects 90
Chemical Command and Control Headquarters 83	<b>Appendix G. Obscurants and How They Work 92</b>
Smoke Generator Units 83	Characteristics 92
Chemical Unit Task Organizations 84	Natural Obscurants 93
Capabilities 85	By-Product Obscurants 94
<b>Appendix E. Smoke Support Sustainment Planning Tables 86</b>	Artificial Obscurants 96
Smoke Pot Consumption 86	<b>Appendix H. Probability of Detection 97-A</b>
Fuel Consumption Tables 87	References 98
	Glossary 99
	Index 103

## Preface

Field Manual 3-50 provides US Army units with doctrine, tactics, techniques, and procedures to use smoke and obscurants to attack and defeat specific enemy targets, sensors, target acquisition systems, weapon guidance systems, and other enemy electro-optical devices. Also, it describes techniques to reduce friendly degradation in smoke.

The scope of this manual is smoke operations at the operational and tactical levels of war. The target audience is maneuver unit commanders and staff officers, particularly the G2/S2, G3/S3, FSO, and chemical officer at corps level and below. Most of the examples depict smoke support for brigade-level operations.

The focus is on synchronized smoke planning — smoke integrated into the commander's tactical plan,

sustained as necessary to defeat the enemy's electro-optical systems and create a "one-way mirror" — one which our forces can both see and shoot through to set the terms of battle.

Smoke is a double-edged sword. Smoke conceals troop movements, slows attacking forces, disrupts command and control, and reduces the vulnerability of critical assets for both friendly and Threat forces. Combat operations in World War II and the Korean War demonstrated that the proper use of smoke enhances mission success and force survivability. In recent times, US forces have reinforced the positive benefits of large-area smoke use at the combat training centers at Fort Irwin, California; Fort Chaffee, Arkansas; and Hohenfels, Federal Republic of Germany.

In battle, the side that employs

smoke correctly and is experienced in limited visibility operations will be more agile and respond faster to changing situations.

Users of this publication are encouraged to recommend additions, changes, or comments to this manual. Key your comments to the pages, paragraphs, and line(s) of text in which you recommend the changes. Provide reasons for each comment to ensure understanding and complete evaluation. Prepare your comments on DA Form 2028 (Recommended Changes to Publications and Blank Forms) and forward them directly to Commandant, US Army Chemical School, ATTN: ATZN-CM-NF, Fort McClellan, AL 36205-5020.

Unless this publication states otherwise, masculine nouns and pronouns do not refer exclusively to men.

## Chapter 1

# Introduction

Common sense tells us what can be seen can be hit and killed on the battlefield. The US Army uses smoke and obscurants to attack Threat reconnaissance, surveillance,

and target acquisition (RSTA) efforts. It also uses smoke to protect the force and to support tactical deception operations. By combining obscuration with maneuver you can

protect your force and deny the Threat the ability to acquire and engage it.

## Historical Perspective

Armies have used smoke to confuse and deceive their enemies throughout history. We can find indications of smoke operations from as early as 2000 B.C. when the burning of damp straw was a common way to smoke enemy positions.

The War Department proposed the use of smoke to President Lincoln during the War Between the States. The idea was not taken seriously at the time and smoke was used sparingly. Documentation of the period reflected in the Cavalry Journal historical archives suggests that "...a little smoke, judiciously laid down, could have changed the entire course of history. Had the South used smoke, Federal forces may not have been able to stop Pickett's charge at Gettysburg even though the Federal force was greatly superior...."

The use of large-area smoke increased drastically during World War II. The British used smoke to effectively screen harbors, factories, and large cities in the United Kingdom from the Luftwaffe's relentless bombing. In 1943, US forces used smoke to protect the supply facilities and invasion fleet at Bizerte Harbor in North Africa from attacking German aircraft. The smoke blanket placed over this area by smoke generator units

resulted in over 3,000 bombs falling harmlessly in and around the area.

The use of smoke and other man-made obscurants can give a commander an edge if applied properly. Natural obscurants can also be used to friendly advantage. The actions of Combat Command A (CCA), 4th Armored Division, during the Lorraine Campaign, in September 1944, demonstrated the use of fog as a combat multiplier.

On 13 September 1944, CCA forced a crossing of the Moselle River north of the heavily defended city of Nancy. On 14 September, CCA was ordered to bypass Chateau-Salins and exploit the weakness to the south. By 1900 hours, CCA began to draw into a perimeter defense around the town of Arracourt. This allowed the Germans to strengthen their position around Chateau-Salins and assemble forces for a major counterattack against the XII Corps right flank. The Fifth Panzer Army moved north, striking at CCA's exposed position around Arracourt. The ensuing battle was one of the largest armored engagements fought on the Western Front.

On the morning of 19 September, a heavy fog concealed the German movement, giving them tactical surprise and protection from Allied

aircraft. Elements of the 133rd Panzer Brigade penetrated CCA's defenses. Two tank destroyer platoons and a medium tank company engaged the 133rd Panzer Brigade. The fog worked to the defender's (Allied forces) advantage, as the limited visibility negated the superior range of the German tank guns. As the fighting surged back and forth through the fog, CCA's tanks and tank destroyers used their mobility to outmaneuver and ambush the larger Panzers.

From 20 to 25 September, the Fifth Panzer Army directed the IIIrd Panzer Brigade and the IIth Panzer Division into a series of attacks against the Arracourt position. Each assault followed the pattern set on 19 September. The Panzers attacked under the cover of morning fog, only to be thwarted by CCA's mobile defense and driven off by armored counterattacks of company or battalion strength.

The defensive actions fought around Arracourt stalled the German offensive. The 4th Armored Division claimed 281 German tanks destroyed, 3,000 Germans killed, and another 3,000 taken prisoner in the fighting. For the German offensive, the ground fog represented a double-edged sword. It provided

them concealment but ultimately led to their demise. For US forces,

it proved to be a significant combat multiplier.

## Description of Smoke and Obscurants

Obscurants are man-made or naturally occurring particles suspended in the air that block or weaken (attenuate) the transmission of a particular part or parts of the electromagnetic spectrum, such as visible light, infrared (IR), or microwaves. Fog, mist, dust, smoke, and chaff are examples of obscurants.

Smoke is an artificially created obscurant normally produced by

burning or vaporizing some product. An example is the vaporization of fog oil to produce smoke from a mechanical smoke generator. We classify US and Threat smoke and obscurants, both currently fielded and developmental, as visual, bispectral, multispectral, or special-purpose obscurants. Visual obscurants defeat the visible through near IR portion of the spectrum; bispectral obscurants

defeat the visible through far IR; multispectral obscurants defeat the visible through millimeter wave; and special purpose obscurants defeat specifically targeted portions of the electromagnetic spectrum.

Appendix G describes the characteristics of smokes and obscurants, how they work, and what obscurants are in the US inventory.

## Uses of Smoke and Obscurants

We can render some electro-optical (EO) target acquisition and sighting devices ineffective; others we can degrade significantly; some we cannot affect at all. As a result of the development of IR and radar devices during World War II and subsequent technological advances, EO devices have supplemented conventional visual methods of target acquisition and aiming weapons. Precision-guided munitions and sophisticated sensors provide the ultimate in lethality on the battlefield:

What can be seen can be hit and killed.

We use visual obscurants to defeat the enemy's battlefield viewers, such as binoculars, weapon sights, night observation sights, and laser range finders. We use bispectral obscurants to defeat the enemy's battlefield viewers and weapon guidance systems such as command line-of-sight or terminal homing systems on antitank and air defense missiles. When developed, we will use multispectral obscurants to

defeat the enemy's battlefield viewers; weapon guidance systems; radar systems; and high-energy, microwave-directed energy weapons.

Table 1, on the next page, is a tactical decision aid for selecting the type of smoke to defeat a particular EO system. Detailed information concerning the types of smokes and obscurants and their effects on EO systems are in Appendixes G and B, respectively.

## How and Where To Use Smoke

Smoke aids in deceiving the enemy, conceals maneuver, and increases your potential force-on-force ratio when your target acquisition systems can see through the smoke and the Threat's cannot (see Chapter 2). For smoke to do this, you must develop a plan to use smoke synchronized with your tactical plan.

Use the military decision model from FM 101-5 as general guidance for planning and executing smoke operations. Commanders must routinely give planning guidance to the staff that answers the following questions:

- What do I want smoke and obscurants to accomplish? (Degrade target acquisition? Conceal the movement of my main attack? Aid in deception?)
- Where and for how long am I willing to sustain this smoke cloud? (Over my own position? Between my unit and the enemy? On the enemy?)
- How much restriction in my own mobility can I accept? (Visibility 50 meters or less? More?)
- How much restriction in my own target acquisition and engagement capabilities can I accept? (If I deny another's laser designators, I also

deny mine, but my thermal sights are unaffected).

- When might on-call hasty or deliberate smoke benefit me? (Where does my decision support tree indicate I may be exposed and need immediate smoke to obscure the enemy?)
- How will countersmoke help me? (If the enemy uses smoke, where and how should I retaliate with smoke to interfere with their synchronization?)

# Categories of Smoke Operations

There are two general categories of smoke operations: hasty and deliberate.

Table 1. Electro-optical systems defeated by smoke.

## Hasty Smoke Operations

Hasty smoke operations are smoke operations conducted with minimal prior planning. They are normally executed by the projected, on-board, and smoke generator units (company- and smaller-size elements) on hand at the time of the engagement. This does not mean that hasty smoke operations are not planned; rather, plan hasty operations as on-call smoke in your deliberate smoke plan. Use hasty smoke operations to support a combined arms force to counter an enemy action or anticipated enemy action of immediate concern to the commander. Hasty smoke operations generally cover a small area for a short duration.

## Deliberate Smoke Operations

Deliberate smoke operations are conducted with detailed planning and are executed by either on-hand smoke assets or with those on hand augmented by corps and theater assets. Deliberate smoke operations normally are synchronized with specific times, events, or locations on the battlefield (for example, when we are within 1,500 meters of the objective, fire six battery volleys of 50-percent high-explosive and 50-percent smoke munitions onto the objective to obscure enemy observa-

Spectral Region	Electro-Optical System	Type of Smoke
Visible 0.40–0.75 mm	Viewers: – Daylight Sights – Naked Eye – Camera Lens – Binoculars/Standard Optics – Battlefield TV – CLOS Missiles (for example AT-3) – Night Sights	All
Near IR 0.75–4.00 mm	Viewers: – SACLOS Missiles (for example, AT-4 and AT-5) – Night Sights	All
	Sensors: – Laser Designators – Laser Range finders	All
Mid-IR 4–14 mm	Viewers: – Passive Thermal Sights	WP, PWP, RP, Type III IR Obscurant, Dust
Far-IR 14–100 mm	Sensors: – Thermal Imagers – Terminal Homing Missiles (AT-6)	WP, PWP, RP, Type III IR Obscurant, Dust
MM Wave and Lower Frequency 1.10 mm	Radar Radio Microwaves	WP and PWP (Instantaneous Interruption Only), Developmental Obscurants
X Ray and Higher Frequency	Directed EMP Nuclear Weapons	Oil Smoke (Attenuation Only), Developmental Obscurants

tion). Deliberate smoke operations normally include multiple pre-planned smoke operations. They cover large areas over long periods

to support the operations of brigades, divisions, and corps.

## Smoke Planning

Each echelon of command plans for smoke employment to support both current and future operations. Integrate smoke into the overall tactical plan, synchronized with key events or decision points. Base smoke planning on the same factors

as the tactical plan: mission, enemy situation, terrain, weather, troops available, time, and distance. Mission considerations include unit capabilities, detailed planning and preparation, employment techniques, communications, intel-

ligence, and whether the unit has successfully operated in smoke previously.

The G3/S3 has primary staff responsibility for planning smoke operations in coordination with the fire support officer (FSO), G2/S2,



G4/S4, smoke unit commander, chemical staff officer, and staff weather personnel. When planning smoke operations, the primary focus must be to attack enemy EO systems and degrade enemy combat effectiveness without significantly degrading friendly command, control, or target acquisition capabilities.

Staff officers must constantly plan to integrate smoke into the tactical plans for both current and future operations. Planning ranges from deliberate plans to provide smoke support for future operations in a 48- to 72-hour window to hasty planning for current operations.

Staffs must develop estimates that define enemy capabilities and our own courses of action, analyze smoke targets, and prioritize smoke resources. They must finally recommend courses of action for the commander's approval. When the commander approves the staff estimates, the staff prepares orders that combine smoke with combat power. Appendix A shows a smoke estimate format and a smoke annex to plans and orders.

## Situation and Target Development

Targeting begins with the commander's guidance and continues through the development of a prioritized list specifying what targets to attack and when to attack these targets (DECIDE) and acquiring high-payoff targets (DETECT) and what will defeat these targets (DELIVER). This process concludes with the commander's decision on which course of action he will select to engage the various targets: maneuver, fire support, and smoke unit support, or a combination thereof. There are two basic processes in the targeting process: situation development and target development.

Situation development and target development are the processes that provide commanders the intelligence and targeting data they

need to plan and fight the close and deep operation. Both processes, conducted simultaneously, incorporate intelligence preparation of the battlefield (IPB) and the intelligence cycle functions. Situation development enables commanders to see and understand the battlefield in sufficient time and detail to employ their forces and weapons effectively. In situation development, the G2/S2 uses IPB to produce a description of enemy force disposition on the battlefield in terms of location, size, type, direction, rate of movement, and activity. For smoke planners, situation development provides information about weather, terrain, enemy disposition, and composition in the area of interest. FM 34-1 provides a more detailed description of situation development procedures.

IPB provides a basis for accomplishing situation and target development. IPB orients the mission planning, collecting, processing, and disseminating efforts of situation and target development. The IPB process includes—

- Threat evaluation. This is a detailed study of enemy forces and their composition, organization, tactical doctrine, weapons, equipment, and supporting battlefield functional systems. For smoke planning, we focus on enemy EO and smoke capabilities as listed in Chapter 2 and Appendix B.

- Evaluation of areas of interest and operation. This is a study of enemy order of battle (OB) for a specific area of the battlefield. For smoke planning, we focus on numbers and probable locations of EO systems.

- Terrain analysis. This is an analysis of the military aspects of the terrain in a specific area. For smoke planning, we focus on the terrain effects on smoke.

- Weather analysis. This is an analysis of the impact of weather on both terrain and friendly and enemy capabilities. For smoke planning, we focus on the weather effects on smoke.

- Threat integration. This is the development of situation, event, and decision support templates. For smoke planning we input the priority intelligence requirement (PIR) and extract actual findings from the decision support template.

## Smoke Estimate Preparation

When the G2/S2 performs the IPB, the chemical officer, in coordination with the G3/S3, FSO, and smoke unit commander, will prepare the smoke estimate. This estimate will go to the G2/S2 and targeting officer for inclusion into the target value analysis (TVA) for fire support planning and to the G3/S3 and chemical staff for smoke target planning.

The chemical staff officer prepares a smoke estimate to recommend courses of action for attacking enemy targets with smoke and obscurants. Besides supporting the commander's estimate, the smoke estimate assists the chemical staff, FSO, and G3/S3 in determining the detailed plan for smoke employment. FM 101-5 contains detailed guidance on the military decision-making process and estimates.

## Smoke Support Plan Development

Simultaneous with preparing the smoke estimate, the staff chemical officer develops a draft smoke support plan. The procedures for preparing a smoke support plan are—

- Coordinate with the commander and staff prior to smoke support planning. Obtain the restated mission.

- Obtain required fire and smoke planning information such as task organization, smoke delivery systems, objectives, axis of advance or sector, and commander's intent.

- Recommend smoke support coordinating measures such as key time, place, and event and no smoke

areas and target allocations (smoke unit targets, artillery targets, and mortar targets) based on available information such as restrictive fire line (RFL), coordinated fire line (CFL), no fire line (NFL), munition availability, and priority of fire.

- Update status displays.
  - Plot locations of maneuver elements and objectives.
  - Plot locations of agreed targets.
  - Develop a smoke support plan.
  - Get target lists from the FSO.
  - Modify target lists as necessary.
- Use the smoke target analysis procedures in Appendix A as guidance.
- Develop a list of smoke delivery assets.
  - Decide the type of support required (for example, smoke versus EO system effectiveness).
  - Decide the time support is required.
  - Decide the best delivery system to engage.
  - Decide the best delivery unit to engage (for example, smoke generator unit, direct support (DS), 155-battery).
  - Prepare and consolidate target lists.
  - Assign smoke target numbers. Appendix A outlines the procedure for numbering smoke targets.
  - Coordinate the smoke support plan with the FSO.
  - Inform or brief requirements for fire support engagement with smoke.
  - Obtain target numbers for targets requiring fire support asset engagement.

- Modify the plan as agreed.
- Ensure the plan is logistically supportable and sustainable.
- Brief smoke support plan to obtain concurrence from the commander (or G3/S3 as required by local policy).
- Brief requirements for fire support engagement with smoke.
- Modify the plan as agreed.
- Decide the support.
- Decide the time.
- Decide which smoke delivery unit (s) will engage.
- Finalize the target list.
- Coordinate the fire support plan changes with the commander or G3/S3 and the FSO.
- Inform or brief them concerning changes made in coordination.
- Modify the plan as agreed.
- Coordinate the smoke support plan with adjacent units.
- Inform or brief them concerning the plan.
- Modify the plan if required.
- Confirm coordination with the commander or G3/S3 and with the FSO.
- Brief the smoke unit leader(s) on the smoke annex to the OPORD.

### **Smoke Support Plan Execution**

The extreme impact of smoke on tactical operations mandates close coordination, control, and planning for contingencies. Command supervision and staff supervision are essential to ensure the use of smoke

enhances rather than degrades mission success.

Commanders must control smoke in their area of operations. Use decision points based on IPB and human feedback to control when you start and stop smoke. Smoke unit leaders monitor the communications nets for the supported unit as well as internal nets. This ensures the commander has an immediate response to start or stop smoke at a particular point or time.

Plan to minimize friendly force degradation from our own use of smoke. Rehearse those contingencies. An antitank position with clear fields of fire may be valueless in dense smoke unless the gunner or section leader has rehearsed movement to previously prepared alternate positions (limited visibility positions).

The preceding paragraphs established the "Why" and "How" of smoke support. The remainder of Chapter 1 answers the "When and Where" and "What" and explains with what delivery systems and delivery units we make smoke. The remaining chapters outline Threat (Chapter 2) and provide doctrine, tactics, and techniques for smoke employment in the offense (Chapter 3), defense (Chapter 4), and other operations (Chapter 5). The manual concludes with smoke support sustainment planning considerations (Chapter 6).

## **Operational Concept for Smoke and Obscurants**

Smoke and obscurants themselves are not lethal. However, when synchronized throughout the depth of the battlefield they enhance the maneuver commander's ability to maneuver. They concentrate combat power against enemy vulnerabilities at the critical time and place. They also reduce his own vulnerability to enemy intelligence and target acquisition. Smoke and obscurants provide the commander with

another means to meet the imperatives of the AirLand battle by-

- Degrading the enemy's ability to see.
- Disrupting the enemy's ability to communicate.
- Concealing friendly forces.
- Deceiving the enemy.
- Providing a means to identify and signal.
- Degrading or defeating directed-energy weapons.

- Enhancing friendly weapon system effectiveness.

The Comprehensive Smoke Study analyzed what happened when US forces used smoke and the adversary used smoke, and the net effect on combat effectiveness when both sides used smoke and obscurants. The lessons learned indicate -

- Smoke favors the attacker. Our force exchange ratio improves 25 to 80 percent.

- Projected smoke is important to success, but resource intensive. Firing units require 400 percent above normal basic loads.
- Large-area smoke is beneficial. There is up to a 30-percent increase in our force exchange ratio. Combined with artillery-delivered WP smoke gives a 75-percent increase in our force exchange ratio.
- You should avoid smoke on friendly antitank guided missile lines of sight.

## Operational Level of War

Operational objectives within a theater of war include the marshaling and sustaining of forces and materiel to conduct successful campaigns. Commanders and staffs at this level of war will plan and conduct smoke operations to—

- Deceive the enemy as to friendly force location, status, and movement.
- Defeat enemy air and satellite reconnaissance efforts.
- Reduce the effectiveness of enemy fire and air attacks.
- Defeat enemy precision-guided weapons.
- Increase force survivability.

## Tactical Level of War

Obscurants can support the movement and positioning of forces on the battlefield and the provision of fire support. They can also conceal the logistical support of forces before, during, and after engagements with the enemy. The objec-

tive of smoke employment is to increase the effectiveness of US operations while reducing the vulnerability of US forces.

Obscurant use supports battlefield deception and enhances friendly combat operations by—

- Increasing friendly force survivability by—
  - Concealing friendly mass and maneuver.
  - Degrading Threat weapon system effectiveness.
  - Attenuating energy weapons.
  - Increasing friendly-to-enemy force ratio.
  - Increasing Threat force vulnerability by—
    - Decreasing Threat rate of advance.
    - Disrupting Threat command and control.
    - Deceiving Threat intelligence collection.

In the offense, the commanders can achieve surprise and protect their force by combining obscurants with maneuver and firepower. Obscurants allow us to reduce our vulnerability through concealment as we mass forces to attack. Obscurants will conceal friendly movements and screen breaching of obstacles and river crossings. They will also negate the stand-off capabilities of enemy long-range antiarmor weapons and interfere with enemy guidance and acquisition systems. Smoke supports tactical objectives by deceiving the enemy as to the exact location, timing, and size of the main attack. It also isolates units for piecemeal destruction.

In the defense, obscurants support disruption of enemy activities and enhancement of friendly operations throughout the battlefield. Smoke will isolate attacking echelons and conceal friendly unit locations. It will screen friendly maneuvers, support deception, and interfere with enemy movement and communications. Obscurants help to preserve forces essential to the mission. Smoke supports tactical objectives by selectively denying air and ground routes and by forcing the enemy into tightened tactical formations, which are easier targets.

In a nuclear environment, temporary massing of friendly forces may create a particularly lucrative target. Dense smoke provides both concealment and some measure of protection against thermal radiation.

## Commander and Staff Considerations

Commanders must be prepared to use smoke to their advantage regardless of whether it is employed by friendly or Threat forces. Commanders and staffs at all levels—

- Consider the use of smoke to enhance friendly scheme of maneuver.
- Avoid developing a predictable pattern of smoke use.
- Anticipate and plan to counter enemy smoke and countersmoke measures (see Chapter 2).
- Train for limited visibility operations to minimize friendly force degradation.

## Operational Continuum

Smoke and obscurants disrupt the enemy's ability to locate, acquire, and defeat our forces across the operational continuum. Use smoke in peacetime, conflict, and war.

### Peacetime

Use smoke in peacetime in support of security assistance operations, show of force, and

peacekeeping operations. Smoke systems may be particularly useful in segregating or isolating violent elements. This creates a sense of isolation among the people. In counternarcotics operations, use smoke to restrict use of airfields and to conceal the movement of law enforcement personnel.

### Conflict

Use smoke in conflict to support all types of military operations. Smoke is useful in insurgency/counterinsurgency and peacetime contingency operations in support of tactical objectives. Smoke systems may be particularly useful in concealing initial insertion of forces.

This would provide surprise and security for our forces.

## War

Use smoke in war to support all operational and tactical operations. Smoke is useful from the onset of

hostilities to protect the force, alter force ratios, conceal maneuvering forces, and give leaders an added dimension of flexibility.

## Spectrum of Conflict

The Army recognizes that under low-intensity conflict (LIC) conditions indirect, rather than direct, applications of military power are the most appropriate and cost-effective ways to achieve national goals. If US involvement requires military action, force protection and identification of Threat RSTA means are critical. In LIC, use projected, generated, and self-defense smoke to –

- Support counterinsurgency operations. Smoke use can protect the force in all phases of counterinsurgency operations. In addition, when identified we use smoke to attack Threat RSTA means. Smoke creates a psychological feeling of isolation. This may reduce the insurgent's will to resist.

- Support terrorism counteraction. Smoke use can restrict use of airfields or facilities and conceal the movements of counterterrorist forces. Use smoke to conceal objectives prior to assault or occupation

by law enforcement or counterterrorist forces.

- Support peacekeeping operations. Smoke use can protect our forces by screening our forces from Threat observation. It can also restrict the effectiveness of combatant target acquisition or weapon guidance systems. Marking smokes are effective for signaling and early warning. In addition, we can use smoke and obscurants to segregate or isolate forces in conflict.

- Support peacetime contingency operations. Smoke use can protect our forces, particularly in a show of force or demonstration. In strikes, raids, and unconventional warfare, use smoke to attack known Threat RSTA means. For example, in a raid on a suspected Threat communications center, friendly forces would—

- Use projected smoke (for example, mortars, rifle grenades, or aviation-delivered smoke rockets) to obscure guard posts and observa-

tion points. This is particularly important when special operating forces are being inserted.

- Use emplaced smoke such as smoke hand grenades to conceal entry into the facility once their presence is known.
- Use projected or emplaced smoke to conceal their exfiltration route and allow them to break contact.

In high-intensity and mid-intensity conflicts, US forces face large, rapidly maneuvering formations on battlefields characterized by sophisticated weapons, high-consumption rates, and extended time and distance. Smoke supports all types of military operations in mid- and high-intensity conflict.

Using smoke and obscurants across the spectrum of conflict will positively influence the outcome of any operation. Chapters 3 through 5 outline tactics for smoke employment to meet the challenges of the spectrum of conflict.

Smoke and obscurants disrupt enemy combat operations throughout the depth of the battlefield. One of the key concepts in AirLand battle is the entire battlefield consists of one single battle fought by one commander with one plan. Obscurant operations must support all levels of command in fighting a unified battle of deep, close, and rear operations.

### Deep Operations

Deep operations disrupt the enemy's movement in-depth, destroy high-value targets behind the enemy's lines, and interrupt enemy

## The Battlefield

command and control at key decision points. Deep attacks are conducted to create "windows of opportunity" by disrupting or destroying follow-on echelons. Smoke systems that support the deep battle include aviation, artillery, smoke generator, and armored vehicle smoke systems.

Army aviation assets deliver smoke rockets from attack helicopters to obscure enemy observation, degrade target acquisition, and mark targets for close air support aircraft. Medium-lift helicopters supporting airmobile operations can move chemical units with smoke generators behind enemy lines. In

addition, we can air transport the chemical company of an airborne division to support airborne operations in the deep battle.

Current artillery-delivered obscurants will seldom have a direct impact on deep strike capability. In the far term, millimeter wave obscurants delivered by rockets onto radar sites will be effective to suppress enemy air defense and counterbattery abilities. Similarly, special purpose obscurants that block certain regions of the electromagnetic radiation will be more effective in disrupting hardened command and control centers than high-explosive munitions.

Deep attacks with armored columns may require the use of smoke self-protection systems. Combat vehicle defensive obscurant systems include vehicular launched grenades and vehicle engine exhaust systems. The prime constraints will be logistical support (fuel and armament).

## Close Operations

In the defense a covering or screening force occupies a sector far enough forward of the forward edge of the battle area (FEBA) to prevent surprise, to force the enemy to deploy their forces, and to gain sufficient time to respond to the Threat. Extensive use of concealing and deception smoke helps to develop the situation by forcing the enemy to deploy. It also denies information about disposition and composition of friendly forces, degrading enemy target acquisition.

Defending forces fill valleys and terrain defiles with visual obscurants to force enemy helicopters above the obscurant cloud, while ground fire is adjusted, using thermal viewers. Use visual and infrared defeating smokes to support countersurveillance and counter-reconnaissance.

Smoke provides concealment for maneuver and counterattack and reduces the effectiveness of enemy target acquisition. It also deceives the enemy about the true intentions of our forces and creates conditions necessary to surprise them. Smoke enables the covering force to delay the Threat advance more effectively.

When advanced positions can no longer be retained, the security force must quickly and efficiently conduct a passage of lines. It must hand the battle off to the main battle area (MBA) units. Smoke pots, smoke generator units, and projected smoke conceal friendly forces and routes during battle handoff.

Obscurants support the decisive battle in the MBA by concealing

battle preparations, denying enemy intelligence information, and concealing maneuver and counterattack. Units conceal areas for real and decoy battle positions during initial preparation and camouflage. Before the battle, mobile units provide smoke in multiple areas until the battlefield is fully prepared.

Use smoke and obscurants aggressively to assist the unit in regaining the initiative. Obscurants isolate enemy echelons, conceal movement of counterattacking forces, and deceive the enemy about friendly intentions. Smoke from smoke units, smoke pots, and enemy smoke lines conceal movement of friendly forces. Artillery- and mortar-delivered smoke blinds enemy armored and antitank elements while friendly forces attack targets from the flanks using thermal viewers. Obscurants separate enemy echelons to preclude supporting and overmatching fire and to facilitate their piecemeal defeat.

Obscurants in the defense of the MBA require careful preparation to preclude an ill-conceived deception; disruption of friendly activities; or poorly-timed, low-visibility retrograde operations. Obscuration will slow friendly activities. Commanders and planners should plan additional time for movement under smoke and obscurants.

## Rear Operations

Because support units normally remain fixed over a period of hours or more, smoke units will normally maintain a large-area haze over brigade and division support activities throughout the early part of the battle. Based on command priorities and resources, brigade and division support areas may be concealed by obscurants from the beginning to the end of the battle. Obscurants used in rear operations include deception and screening of vital targets. Such targets include communications centers, ammunition supply points, motor pools,

tank parks, assembly and staging areas, and critical portions of main supply routes.

At the operational level, the protection of key transportation and logistics activities is critical to sustaining the force. Echelons above corps must plan for obscurants in the defense to conceal static operations. Ports and terminals; fixed rail facilities such as bridges, tunnels, and rail yards; logistics-over-the-shore sites; dams; locks; trailer transfer points; and critical points along main supply routes must be covered. Obscurants may also provide limited protection for nonstatic operations such as water transport, railroad operations, inland waterways movement, and convoys. Commanders and staffs must carefully plan operations to ensure that the use of friendly obscurants at one logistics facility does not impede activities at another.

Smoke can assist in defeating or delaying enemy airborne and airmobile operations. Place smoke over potential drop zones and landing zones in rear areas to conceal them and force the enemy aircraft to remain exposed to our air defense assets longer. This is particularly useful when you have significant intelligence indicators that airborne or airmobile operations are imminent, as smoke may deny the enemy the ability to insert those forces at all.

In the event of enemy breakthrough, rear sites and some rear area forces will not be able to maneuver away from an attacking Threat force. They will have to defend in place. Placing smoke on rear operations will conceal them from observation. However, this will degrade their operations. Smoke may be placed on the Threat forces, in coordination with electronic warfare and deception assets, to isolate the Threat units and prevent resupply, relief, or reinforcement prior to their destruction.

# Battlefield Applications of Smoke

Smoke has four battlefield applications that support combat operations: obscuring, screening, protecting, and marking.

## Obscuring Smoke

Obscuring smoke is smoke delivered directly on or immediately in front of enemy positions to blind or degrade their vision both within and beyond their location. Use obscuring smoke to attack and defeat enemy target acquisition and guidance systems at their source. Projected means, such as artillery, mortars, rockets, and rifle grenades, generally deliver obscuring smoke.

For example, smoke delivered on an enemy antitank guided missile (ATGM) position may prevent the system from acquiring or subsequently tracking targets, thereby reducing its effectiveness. Employment of obscuration smoke on an attacking armored force may cause it to vary its speed, inadvertently change its axis of advance, deploy prematurely, and rely on nonvisual means of command and control.

## Screening Smoke

Screening smoke is smoke delivered in areas between friendly and enemy forces or in friendly operational areas to degrade enemy ground or aerial observation or both. It also defeats or degrades enemy EO systems. In general, use screening smoke to attack enemy target acquisition and guidance systems by placing smoke between the friendly unit and the sensors. Generated means, such as smoke generators, smoke pots, and smoke hand grenades, deliver screening smoke.

For example, employ screening smoke to conceal ground maneuver, breaching and recovery operations,

key assembly areas, and supply routes. There are three visibility categories for screening smoke that the supported unit commander uses to establish the visibility requirement for a smoke mission. These are —

- **Smoke haze.** A smoke haze is a light concentration of smoke placed over friendly areas to restrict accurate enemy observation and fire. It is not dense enough to disrupt friendly operations within the screen. A smoke haze is defined as a concentration of smoke that would allow an individual to identify a small tactical vehicle between 50 and 150 meters away, but no farther than 150 meters.

- **Smoke blanket.** A smoke blanket is a dense, horizontal development of smoke used over friendly areas to conceal them from enemy ground and aerial observation. A smoke blanket may hamper operations of friendly troops by restricting movement and activity within the screen. It provides maximum concealment. It is a concentration of smoke that would allow the identification of a small tactical vehicle from 0 to 50 meters but no farther.

- **Smoke curtain.** A smoke curtain is a dense, vertical development of smoke. It is placed between friendly and enemy positions to prevent or degrade enemy ground observation of friendly positions. Since the smoke curtain is not placed directly on friendly troops, it will not hamper friendly operations. Commanders should use smoke curtains when friendly forces have air superiority or air parity. It does not prevent aerial observation; however, it may force aircraft to fly higher in order to see behind the curtain, thus increasing vulnerability to air defense weapons. In general, smoke curtains will defeat sensors in the

visual through mid-infrared portions of the spectrum depending on the concentration of the smoke.

## Protecting Smoke

Protecting smoke is smoke used to defeat enemy guidance systems or to attenuate energy weapons on the battlefield. Smoke and obscurants have the ability to reflect, refract, or absorb energy. When enemy gunners have already fired ATGMs or have used laser designators, use protecting smoke to immediately screen vehicle movements and defeat enemy guidance links. In an active nuclear environment or when threat of nuclear weapon use is high, use protecting smoke to attenuate the thermal energy from nuclear detonations.

When the enemy possesses directed-energy weapons, use smoke or obscurants to degrade the effects of those weapons. Directed-energy weapons include lasers; high-power microwaves; particle beams; and non-nuclear, directed electromagnetic pulse. A detailed description of the effects of smoke and obscurants on directed-energy weapons is in Appendix B.

## Marking Smoke

Marking smoke includes smoke used to mark targets, identify friendly positions, and provide for prearranged battlefield communications. The smoke means used for identification or signaling smoke are normally projected means and smoke hand grenades. For example, use helicopter-delivered smoke rockets to mark a target for destruction by close air support aircraft, artillery, or mortars. Use smoke hand grenades to signal aircraft.

# Smoke Delivery Means

The primary factors that affect delivery of smoke onto a target are the smoke weapon system (delivery means and smoke agents) and terrain and weather conditions (steering winds and temperature gradients). Appendixes C and G detail smoke delivery means and smoke agents, respectively.

## Smoke Delivery Systems

In general, there are three means for producing smoke: projected, self-defense, and generated smoke devices and systems.

### Projected Smoke

Projected smoke is smoke produced by artillery or mortar munitions, naval gunfire, helicopter-delivered rockets, and bombs and generator smoke from fixed-wing aircraft. The advantage of using projected smoke munitions is you can place smoke directly on a deep, close, or rear target.

The disadvantage of projected smoke is that most projected smoke devices and munitions are lethal; they cannot be used on or near friendly forces. Most unit basic loads for munitions are insufficient for sustaining smoke on a target. The exception to this is generator smoke from fixed- and rotary-wing aircraft, which is considered a projected smoke system because of its ability to obscure deep targets.

Projected smoke can support both short- and long-duration missions based on the availability of ammunition. Combine use of projected smoke munitions with other smoke employment means throughout the battlefield.

The ideal battlefield applications for projected smoke systems are producing obscuring smoke, initiating screening smoke, and marking targets. For example, use projected smoke systems to place smoke on enemy intelligence gathering assets, ATGM positions, and artillery for-

ward observers. Also, use them for initiating screening smoke forward of an attacking force that smoke generators will sustain.

### Self-Defense Smoke

Self-defense smoke is smoke produced by smoke grenade launchers and the vehicle engine exhaust smoke system (VEESS), which we mount on most armored vehicles. An advantage of this system is rapid smoke production and responsiveness to the small unit leader. Disadvantages include danger to dismounted troops with the grenade launchers, interrupting your own target acquisition while taking evasive maneuvers, and additional fuel consumption for VEES.

The ideal battlefield application for self-defense smoke devices is to conceal armored vehicle movements and to reduce vulnerability to attack by enemy antiarmor weapons. The devices function as follows:

- Armored vehicle smoke grenade launchers. Mounted on M88, M113, M60, M1, M2, and M3 families of armored vehicles, smoke grenade launchers provide rapid obscurant production to assist the vehicle in self-defense. The launchers deliver the obscurant in front and/or to the flanks of a vehicle by smoke grenades electrically fired from the vehicle.
- Vehicle engine exhaust smoke system. The VEES injects diesel fuel into the engine exhaust system. The fuel then vaporizes and is released into the air, where it condenses and produces smoke. Vehicles that currently have the VEES include the AVLB, LEV, M88A11, M60, M1, M2, and M3 families of combat vehicles.

### Generated Smoke

Generated smoke is smoke produced by smoke pots, smoke grenades, and smoke generators. Steering winds deliver generated smoke to a target. Combine generated smoke with projected

smoke to provide depth of coverage throughout the battlefield.

Generated smoke can cover small and large areas for up to an indefinite period of time based on the availability of logistical support, particularly fuel.

- Smoke pots and smoke grenades. You can pre-position these. They do not require an operator. You can ignite them manually or electrically. Use these smoke devices in hasty smoke operations because of their relatively short burn time and ease of access. The ideal battlefield applications for smoke pots are initiating screening smoke, marking smoke, and providing smoke unit self-protection. Smoke hand grenades are best for small-area screening smoke (squad-size maneuver) and marking smoke.

- Smoke generators. Smoke generator units produce large volumes of smoke to support hasty or deliberate smoke operations. Smoke generator units require a stand-off distance from the target based on wind speed and direction. Smoke generators are ideal for large-area smoke missions of long duration. They require detailed planning for logistical support. The ideal battlefield applications for smoke generators include screening, protecting, and sustaining obscuring smoke.

There are two concepts for employing smoke generators: mobile and stationary.

**Mobile smoke** is smoke produced while the system is on the move. Mobile smoke units normally are positioned well forward on the battlefield. They have the advantage of maneuver, but are exposed to more enemy weapon systems. They have a self-concealment ability that enhances their survival, and they can make smoke from a freed position or while moving. Mobile smoke systems rely heavily on passive operations security (OPSEC) measures to enhance their survivability.

Mobile smoke is supplied by units equipped with M1059 mechanized smoke carriers or motorized M157 smoke generators.

The M1059 is an M113 armored personnel carrier (APC) equipped with the M157 smoke generator set. This system can support armored and mechanized forces well forward. It is less vulnerable to small arms and indirect fire than wheeled systems due to its armored plating. Its tracked chassis provides it with the ability to move with its supported unit both on and off the road.

The motorized M157 smoke generator is an M1037 HMMWV equipped with an M157 smoke generator set. This system can provide mobile smoke to light infantry and specialized units. This system is vulnerable to small arms and indirect fire.

**Stationary smoke** is smoke produced from a fixed location, normally by units equipped with M3A4 mechanical pulse jet smoke generators mounted on M998 HMMWVs or M151 1/4-ton vehicles with trailers. Units move their vehicles and smoke generators into positions on a smoke line and then produce smoke. These units are limited by their mobility and require more time to set up and depart an area. They are well-suited for large-area smoke missions conducted in rear areas.

### Weather and Terrain Effects

Steering winds actually carry the smoke and determine its direction, speed, and downwind travel distance. Temperature gradients are normally based on the time of day. Temperature gradients affect the

height, density, duration, and travel distance of smoke. There are three types of temperature gradients: lapse, neutral, and inversion.

Since steering winds carry smoke, smoke usually follows the contours of the earth's surface. On flat, unbroken terrain and over water (open terrain), smoke streamers take longer to spread out and mix with other streamers. Obstructions, such as trees and buildings, tend to break up smoke streamers. The streamers may then re-form, cover a larger area, and create a more uniform cloud than over open terrain. Large hill masses and very rugged terrain cause strong cross currents of wind and tend to create holes and uneven dispersal of the smoke cloud.

Appendix F details the effects of weather and terrain on obscurants. It also gives a summary of the best and worst employment conditions.

## Smoke Units

Smoke generator units are assigned to chemical battalions under chemical brigades at corps, to chemical battalions at TAACOMs, and to divisions. Detailed information concerning the modified or living tables of organization and equipment (MTOEs/LTOEs) and capabilities of these units is in Appendix D.

The platoon is the lowest echelon of command for smoke units that is self-sufficient. Table 2, below, out-

lines the smoke coverage capabilities of smoke platoons.

### Tactics, Techniques, Procedures, and Unit Guidelines

Smoke tends to draw enemy attention and fire especially when used over friendly areas. The effect of enemy fire can be minimized by detailed planning, synchronizing all smoke assets with firepower, and

limiting exposure of smoke assets to that fire.

### Tactics, Techniques, and Procedures

The commander that "owns" the terrain is responsible for controlling the smoke. Place smoke before the enemy can pinpoint targets. Employ smoke during hours of darkness and limited visibility periods (rain, fog, ice fog, snow, sleet) to enhance its effectiveness. Synchronize all smoke assets for maximum impact

Table 2. Smoke platoon coverage capabilities.

Stationary Smoke	No. of Generators	No. of Point Sources	Average Cloud Parameters			
			Crosswind Width		Downwind Depth	
			Haze	Blanket	Haze	Blanket
	24	24	1.00–3.40 km	0.50–1.70 km	0.65–10.00 km	0.65–10.00 km
	24	12	0.50–1.70 km	0.30–0.90 km	0.65–10.00 km	0.65–10.00 km
	12	6	0.30–0.90 km	0.15–0.50 km	0.65–10.00 km	0.65–10.00 km
Mobile Smoke	12	6	0.55–1.40 km	0.50–1.20 km	0.15–3.60 km	0.05–1.40 km
	14	7	0.60–1.50 km	0.55–1.30 km	0.15–3.60 km	0.05–1.45 km



against the enemy. Coordinate smoke employment with adjacent units and all units in the operational area to minimize friendly unit degradation.

Understand that smoke compresses the battlefield by limiting visibility. Training soldiers to operate in smoke reduces the degradation caused by smoke. It also reduces psychological impact such as confusion, fear, and isolation on troops.

Smoke cloud size should be large enough to prevent the enemy from saturating the entire smoked area with fire. The target should be offset from center within the smoke. A rule of thumb is for the screen to be five times the size of the target. Avoid patterns for smoke employment. Avoid placing smoke over the center of your target every time. Maneuver using the flanks and edges of the smoke alternatively with the center.

To support tactical deception, employ smoke over other likely areas to dilute the volume of fire and draw attention to the areas of little or no importance. The smoke should approximate the principal smoke cloud in size. Establish and enforce mobile smoke control measures. The smoke control officer controls the smoke operation from a vantage point allowing target observation, ensuring it is completely concealed by smoke. When using self-defense smoke, ensure the entire squad, section, or platoon uses the smoke simultaneously to preclude drawing attention to a lone vehicle.

Start the smoke mission prior to operation start time and continue well beyond the end of the operation. For example, a river crossing is scheduled for the time from 0500 to 0700. Start smoke at 0400 and stop smoke at 0800 to confuse the enemy as to the exact crossing time and size of the force.

Limited visibility positions, preplanned and previously prepared, will minimize degradation caused by friendly or Threat use of

smoke. Rehearsal of displacement under smoke will help you avoid confusion and disorientation and rapidly restore engagement capability.

### **Unit Guidelines**

Smoke units are vulnerable to enemy direct fire weapons. Use the following guidelines when employing smoke generator units. Smoke units should, whenever possible, avoid prominent terrain features and locations that would permit accurate map firings or fire through adjustment from a known point.

Do not use mobile smoke vehicles to lead the attack. Use them to screen the flanks or main body maneuvering forces. Do not employ smoke units less than a platoon-size element. Use stationary smoke units to conceal rear area facilities and light infantry forces.

### **Command and Support**

Smoke units operate under two types of relationships: command and support. A command relationship reflects the chain of command and degree of authority. A support relationship represents the manner in which the maneuver unit is to be supported.

In the tactical planning process the staff recommends the appropriate command or support relationship between the chemical unit and the supported unit. This relationship defines the specific responsibilities between supporting and supported units. Generally, smoke units at corps and division levels establish support rather than command relationships. Direct support (DS) is the preferred support relationship for company-size and larger chemical units. Attachment is the preferred command relationship for chemical platoons.

### **Organization and Principles**

Smoke units work most efficiently under the control of a parent chemi-

cal unit. This organization permits close control and the most productive use of all assets. The commander continuously monitors the progress of assigned tasks. He shifts elements where the need is greatest throughout his area of operations. On the other hand the supported unit commander at the lowest level gets greater responsiveness when the chemical unit is under his direct control. He determines the task organization and gives missions directly to the units under him.

Providing smoke units in a command or a support relationship is a balance between the needs of the higher commander for flexibility and the needs of the subordinate commander for responsiveness. The corps may provide each committed heavy division with one motorized and one mechanized smoke company. Light infantry divisions are normally provided a dual-purpose smoke/decontamination company. Units are provided in either a command or support relationship.

For brigades already in contact or when contact is imminent, it is also appropriate for the division to allocate chemical units in an OPCON or attached status. Brigades, in turn, can provide chemical assets directly to their battalion task forces only when they receive the chemical assets from the division in a command relationship. Otherwise, the chemical unit commander deploys his subordinate elements based on his estimate.

At each echelon, commanders use organizational principles, derived from the AirLand battle imperatives, to guide the employment of chemical units. These principles include the following:

- Task organize to meet requirements. Mission requirements drive size and composition of task forces. A mix of chemical units is often necessary to achieve the proper balance of capabilities.
- Task organize by platoons.
- Give priority to the main effort. There are not enough chemical assets on the battlefield to handle all

tasks. Chemical units are not spread evenly across the battlefield but are concentrated with the main effort to ensure its success.

- Integrate chemical support with maneuver and fire. The scheme of maneuver governs the use of smoke and reconnaissance assets.
- Do not hold smoke units in reserve. Smoke assets are too scarce and valuable to be held out of the fight. They must refit quickly and return to their primary mission.
- Make logistically sustainable plans. Resources are always limited. The availability of fuel and fog oil restricts chemical unit ability to execute smoke missions. Conduct detailed planning for chemical unit sustainment and supporting logistics.
- Maintain effective command and control. Effective plans use all available controlling headquarters and hand off operations smoothly between them.

### **Responsibilities**

When supported by a smoke generator unit, both the maneuver unit commander and the smoke unit commander have specific sets of responsibilities for planning and coordinating the smoke mission. Smoke missions involve close coordination between the supported unit commander and staff and the smoke unit commander. Commanders must use the same troop-leading procedures for smoke assets as they will for their maneuver units, ensuring smoke unit commanders have adequate time and resources to plan and prepare for smoke support.

### **Maneuver Unit Commander's Responsibilities**

The maneuver unit commander is responsible for the overall tactical

operation. This commander must execute coordination with all units participating in or influenced by the smoke operation. He defines smoke support requirements to include—

- His intent.
- Visibility criteria within the smoke.
- Location and size of the smoke target.
- Time for effective smoke to be on the target.
- Duration of effective smoke on the target.
- Security of smoke assets.
- Immediate support available for the mission.
- Preparation of a smoke annex for the operation.

### **Smoke Unit Commander's Responsibilities**

When the smoke plan calls for support from a smoke generator unit, the commander of the smoke unit is responsible for all activities concerning establishing and maintaining smoke on the designated target. Based upon information from the maneuver commander, the smoke unit commander performs the following tasks:

- Plans for map, air, or ground reconnaissance.
- Coordinates the mission with supported and adjacent units.
- Selects and coordinates smoke lanes (mobile smoke) or smoke lines (stationary smoke).
- Coordinates communications nets.
- Provides input for the smoke annex.
- Identifies additional support requirements within the limitations of command or support relationships.

### **Chemical Staff Officer's Responsibilities**

The chemical staff officer plans and monitors the execution of the

smoke plan, in coordination with the FSO and smoke unit commander. The procedures for smoke planning have been discussed. The procedures for monitoring execution are—

- Direct the chemical staff in monitoring the smoke support plan.
- Monitor planned smoke engagement by fire support assets:
  - Coordinate with FScell.
  - Determine whether planned fire was executed.
  - Make changes as necessary.
  - Report changes as required.
  - Update status displays.
- Monitor planned smoke engagement by smoke unit assets:
  - Monitor the smoke unit net.
  - Determine success (Smoke on target on time? Did it achieve purpose?).
  - Make changes as necessary.
  - Report changes as required.
  - Update status displays.
- Monitor planned smoke employment by maneuver units (for example, VEES and smoke pots):
  - Monitor the appropriate command or maneuver unit net.
  - Determine success (Smoke on target on time? Did it achieve purpose?).
  - Make changes as necessary.
  - Report changes as required.
  - Update status displays.
- Monitor immediate calls for smoke:
  - Monitor the appropriate net (FScell and smoke unit).
  - Determine if smoke support is required.
  - Determine the best asset to engage. (Note: Fire support assets have the quickest response time.)
  - Respond if necessary to coordinate smoke support from other than fire support assets.
  - Update status displays.

## Chapter 2

# Threat

US forces may have to fight enemies ranging from sophisticated armored forces of Warsaw Pact and the more advanced emerging countries to unconventional forces of the Third World. The reconnaissance, surveillance, and target acquisition (RSTA) capabilities of our potential adversaries range from binoculars and night vision devices to laser and thermal imaging systems. We must focus our training, doctrine, and tactics in smoke and obscurants on degrading and potentially defeating these types of systems.

The training begins with identifying the location, types, capabilities, and employment procedures of enemy systems on the battlefield. The FM 100-2 series covers the Soviet Army and North Korean Army. The Cuban Forces Handbook, DDB-2680-62-86, dated May 1980 and similar handbooks for other countries are excellent sources of information on Third World

countries. These are excellent references for unit organization and equipment, operations and tactics, and specialized warfare.

The smoke capability of our potential adversaries ranges from field expedient methods to extensive smoke-producing equipment and organizations in the field. Clearly the most significant Threat smoke capability resides within the Soviet Union. Their continued emphasis on adapting existing smoke assets to tactical missions and the development of new smoke systems allows Soviets to employ smoke in depth and in large areas for extended periods.

Historically, the Soviets relied heavily on smoke. In many instances smoke use was directly responsible for operational success. One Soviet writing states that during an offensive action smoke screens can reduce their losses of combat vehicles by 60 percent to 80 percent. In World War II, the Soviets

established smoke lines up to 100 kilometers long, maintaining them for several days, weeks, and months.

The Soviets state that smoke carries more importance today than in World War II. This is due to the growth of highly sophisticated, long-range target acquisition systems that relatively inexpensive smoke and obscurants can defeat. They believe that smoke and obscurants can degrade and potentially defeat the use of optical, laser, night vision, and even thermal imaging systems. For this reason the Soviets plan that they will use smoke whenever and wherever the tactical situation permits.

For these reasons, our intelligence preparation of the battlefield (IPB) must include both Threat RSTA and smoke capabilities. This chapter outlines Threat RSTA and smoke employment doctrine. Chapters 3 through 5 outline doctrine and tactics to attack Threat RSTA efforts and protect the force.

## Reconnaissance, Surveillance, and Target Acquisition

The effective employment of battlefield smoke and obscurants requires an understanding of Threat RSTA capabilities and how these capabilities support Threat operations. The Soviets define reconnaissance as the collection of intelligence information about the location, disposition, composition, number, armament, combat preparedness, character of activities, and intentions of the enemy in the interests of combat.

Threat RSTA encompasses all methods, such as photographic intelligence (PHOTINT), imagery intelligence (IMINT), and human intelligence (HUMINT). The most reliable methods and therefore the most used methods of RSTA are also easily defeated by smoke and obscurants. The Threat groups these methods into three major areas (aerial, ground, and artillery) that encompass the strategic, operational, and tactical depth of the battlefield.

Aerial reconnaissance sources are the satellites, front/army aviation assets, rotary-wing aircraft, and remotely piloted vehicles (RPVs).

Ground reconnaissance includes long-range reconnaissance units of front/army and divisional organizations and special reconnaissance, such as NBC, engineer, and medical reconnaissance.

Artillery reconnaissance uses artillery observation posts through direct observation, supplemented by radar, sound, and flash ranging, and

information resulting from electronic means.

Threat forces will conduct reconnaissance to acquire information on US nuclear weapons, force disposition, and intentions. In the Soviet ground forces, dedicated reconnaissance units will conduct aggressive RSTA for commanders from the front down to regiment.

## **Aerial Reconnaissance**

Satellite, or "cosmic" reconnaissance, includes photography and television. It is controlled by the GRU (general staff's main intelligence directorate). One reconnaissance satellite version contains a video system on which images are stored and later retransmitted to Soviet ground stations.

Aerial reconnaissance is the principal method of gathering target intelligence. It provides the most timely and reliable information on the character and location of targets, particularly those in the enemy rear. Aerial reconnaissance recognizes four major categories of targets:

- Nuclear weapon systems and storage depots.
- Active and potential airfields.
- Defensive positions and systems (AD, C3, EW).
- Reserves, logistic facilities, and approaches.

Front air forces normally include an air reconnaissance regiment, but may have as many as three. These regiments are self-contained and process the information they collect. There are 24 to 40 aircraft per regiment. Their collection capabilities include fixed-frame and strip photography, infrared (IR) photography, television, and side-looking airborne radar (SLAR). An example is the FOXBAT B, which carries five nose-mounted cameras and IR linescan equipment. It provides a coverage corridor of up to 70 kilometers. The aerial television with down-link does not give the resolution of still photography, but it is near-real time. About half of the Soviet reconnaissance aircraft

can transmit their information in-flight. High-performance aircraft and helicopters can be equipped with laser range finders and designators.

Reconnaissance aircraft fly at a high speed and low altitude, out to 600 kilometers beyond the forward edge of the battle area (FEBA). However, certain reconnaissance aircraft, such as the FOXBAT B (with visual and IR cameras) and the FOXBAT D (with SLAR), may perform their missions at high altitude without having to cross their forward line of own troops (FLOT).

Front and army RSTA assets may include a squadron of drones, commonly the DR3. Drones may have vertical and side-looking cameras, using visual and IR film. A drone may also carry a video with real-time down-link, though this would reduce its range. One drone squadron could launch 20 missions a day.

Aerial reconnaissance is particularly critical to the initial air operation. Predesignated strikes are planned in detail. Maps and terrain models are used to familiarize pilots, plan approach and departure routes, and determine attack techniques and routes. The vulnerability of high-performance aircraft to ground-based air defense necessitates a low-altitude (ideally, 50 to 100 meters), high-speed approach in minimum time. The pilot has three to six seconds to identify his target. Helicopter squadrons at army and division level will fly missions in support of engineer, chemical, and artillery reconnaissance.

## **Ground Reconnaissance**

Reconnaissance units are assigned to all echelons of the Soviet force structure, from regiment to front. Reconnaissance units are equipped with tanks, BMPs, BTRs, and BRDM2 scout cars, and reconnaissance variants of each. Specialized vehicles perform engineer and NBC reconnaissance.

The BRM is a BMP variant mounting the TALL MIKE ground surveillance radar. Some units will have the PSNR (portable information gathering station), a man-pack radar, or a mixture of both. Detailed information on the reconnaissance units' organization and equipment can be found in FM 100-2-3.

Ground reconnaissance is primarily the concern of the tactical commander at division and below. His or her interest is the enemy and terrain to the immediate front, out to 100 to 150 kilometers. Tactical ground reconnaissance units operate out to 50 kilometers in front of the division. Airborne reconnaissance teams can operate out to 100 kilometers.

The information gathered directly supports the plan of fire and maneuver. Reconnaissance units will operate as patrols of two to three vehicles. The greatest effort will be directed toward suspected enemy strength and primary axes of advance. These patrols will avoid combat if possible. They will concentrate their efforts on finding enemy units, determining their strength, disposition, and weapons. As the battle is joined, these patrols will attempt to penetrate the FEBA to report on rear area activities, movement of reserves, and location of supply routes.

In addition to dedicated reconnaissance units, the organization of the regiment in march maximizes reconnaissance. To maintain the momentum of the attack, the regiment in march allocates its combat power forward in increments of one-third. This march formation assures that the main body is not impeded by a small enemy force.

The first element is the combat reconnaissance patrol (CRP), consisting of a reinforced platoon. Engineer and NBC reconnaissance assets usually will be attached to the CRP. The CRP engages enemy units to determine strength and disposition. If the CRP cannot overcome the enemy, it will attempt to

fix the enemy in place to facilitate the employment of its parent, the forward security element (FSE), consisting of a reinforced company. Next follows the advance guard, a reinforced battalion.

Target acquisition for direct fire begins early in the battle. A PRP3, with its SMALL FRED target acquisition radar, will be found with the advance guard, if not sooner.

Most Soviet combat vehicles carry active IR for night vision and fire control; many are equipped with laser range finders. Laser range finders in vehicles and artillery units are usually Nd: YAG (Neodymium: yttrium aluminum garnett) operating in the visible spectrum at 1.06 microns. Some Third World countries are capable of and have installed thermal imagers rather than active IR optics on their com-

bat vehicles fleetwide. This capability increases the Threat, because reconnaissance and combat units will be able to detect and engage friendly units using these devices.

## Artillery Reconnaissance

A network of observation posts controls artillery fire. Artillery observation posts locate targets and reference points. They transmit the data back to the firing batteries and adjust fire. Some observation posts will be located with the advance maneuver elements. Armored command and reconnaissance vehicles (ACRVs) (which function as fire direction centers as well as observation posts) carry day/night observation devices and laser range finders

for target acquisition, topographic survey equipment for location data, and a fire direction computer.

Battlefield surveillance radars also support target acquisition and fire adjustment. The PRP3 mobile observation, a BMP variant, is found in each howitzer battalion. It carries the observation devices of the ACRV and the SMALL FRED radar, which detects targets and adjusts fire out to 20 kilometers. The BIG FRED battlefield surveillance radar, mounted on an MTLB, a light transport combat vehicle, is found in the target acquisition battery of the artillery regiment. The MI2 HOPLITE from the division helicopter squadron is also used for target acquisition and fire adjustment.

## Combined Arms Operations

The Soviets believe the tank to be the keystone of the combined arms operation. Their concern about NATO antitank capabilities gives them great incentive to develop

both improved and more extensive obscuration capabilities and tactics. Soviet writings often cite the Arab-Israeli War of 1973, in which ATGMs destroyed over one-third

of Israeli armored vehicles in one week. Their doctrine reflects this concern over defeating enemy antitank weapon systems.

## Threat Smoke Tactics, Techniques, and Procedures

In addition to the three battlefield smoke applications, we can expect the Threat to follow several guidelines when using smoke. These include the following:

- Cover an area five times the size of the target, with the target off center within the smoke.
- Light dummy fires or use flares within the smoke to give the false impression of a hit when enemy fire falls within the smoke.
- Initiate the smoke two to three hours before starting the operation; sustain the smoke along a wide front to conceal river crossing operations.
- Place smoke on both sides of the river during crossing operations.
- Make maximum use of floating smoke pots and smoke barrels to cover the crossings.

- Use decoy smoke at one or more likely crossing sites in an attempt to deceive our forces.
- Use smoke to conceal aerial reference points.
- Use smoke to conceal important locations and possible targets such as troop concentrations, crossing sites, bridges, railroad junctions, and unloading areas.
- Screen flanks of attacking echelons.
- Use illumination rounds in conjunction with blinding smoke to destroy night vision on the objective and illuminate the target.
- Screen fronts of advancing maneuver echelons.
- Screen movement of guns and other weapon systems into firing positions and from position to position.

- Use smoke to screen the activities of engineer units when clearing minefield and to mark passages through engineer barriers.
- Use smoke to screen logistics routes and activities that are within range of our fire and observation.
- Use smoke to mark targets for aircraft, artillery preparation, and signaling purposes.
- Use blinding, camouflage, and decoy smoke to conceal the direction and time of attack to minimize losses.

**Note:** Reliable communication and continuous coordination among units making smoke, units using smoke, forward air warning assets, and air defense systems are essential.

## Threat Offensive Smoke Use

Threat smoke doctrine states that they will use smoke whenever and wherever the tactical situation permits. The extent they use smoke in any offensive operation depends largely on the amount of time available to plan and coordinate for the use of smoke in support of the operation. Smoke usage is also dependent on other variables, such as weather, terrain, and the tactical situation. Nevertheless, we can deduce several doctrinal norms for our IPB in regard to Threat smoke use in the offense. Expect the Threat to—

- Use an intense initial artillery preparation with HE and smoke munitions fired for shock and suppression
- Use sustained HE fire to cause attrition to defenders; this also creates large quantities of dust that stay aerosolized after three to four volleys.
- Place blinding HE dust and smoke on or in front of defensive positions.
- Use smoke to deny acquisition, degrade armor or antiarmor guidance systems, and with toxic smokes create casualties.
- In the main attack area, make smoke three to five times wider than the zone of attack.
- On the Threat side of the FLOT, use smoke pots and generators and limited VEES smoke to camouflage and protect the attacking force's advance from long-range helicopter and indirect fire.
- On the US side of the FLOT, use HE-created dust, projected WP/PWP smoke, and on-board smoke to degrade acquisition and armor or antiarmor guidance systems.
- Increase artillery tempo as attack force approaches the FLOT
- Shift HE and smoke fire to isolate the zone of attack when the attacker is 400 to 1,000 meters from our defense.
- Conduct the final assault unencumbered by their own obscurants

- After a Threat attacking force passes through the FLOT to our side of the FLOT, use consecutive lines of fire with HE and WP/PWP to provide additional blinding smoke.

- Use VEES/grenades on the US side of the FLOT only on command of the company and battalion commander when required for additional protection.

### Threat Smoke Example

The following example illustrates the Threat's use of smoke in the offense. The example does not include consideration of either terrain or local meteorological conditions; therefore, it is largely mission, enemy, terrain, troops, and time available (METT-T) independent. The example centers around the type, extent, and time frame in which the Threat would use obscurants. The example does not consider our countermeasures and does not represent US Army doctrine.

In meeting engagements, the Threat attempts to seize the initiative to either overwhelm or force the opponent into the defensive. These tactics generally occur when covering forces, guard forces, patrols, and units moving to contact encounter the enemy, either intentionally or unintentionally. They are normally conflicts of a few hours duration. A meeting engagement will probably occur more frequently than any other encounter and involve the least amount of deliberate use of smoke and obscurants.

*A Threat reinforced motorized rifle battalion (MRB) has penetrated our defensive positions. A second-echelon unit has exploited the breakthrough by continuing the march into our rear area. At H - 9, both sides have located each other, with neither screening force large enough to initiate combat. Therefore, they remain in contact until either side can bring forward a larger force. The distance between the opposing*

*forward elements is 1,300 meters. The CRP is part of the reinforced motorized rifle company (MRC), which is part of a reinforced MRB. The mission of the FSE is to destroy our reconnaissance forces and to destroy or fix our lead company, thereby fixing our force in position. Twenty minutes behind the FSE is the reinforced MRB (minus the advanced guard) that is to actually conduct the attack.*

*At H-hour supporting artillery deploy and fire a WP round from each of two 122-millimeter guns to mark the enemy's flanks. The FSE is moving forward and will establish the FLOT along the screen line of the CRP. The advanced guard is moving forward at a rate of 30 kilometers per hour.*

*The artillery and mortar units begin their fire at H + 1 minute, using HE rounds on the objective. The FSE has deployed along the FLOT with its attached tank platoon in the northern sector.*

*At H + 9 minutes, the FSE's combat vehicles initiate camouflage smoke with their VEESs (Figure 1, next page). The artillery and mortar units increase their rate of fire. Two minutes later (H + 11 minutes) the two platoons in the northern sector shut off their VEES and fire a half volley of their smoke grenades. These two platoons will distract attention from the advanced guard, which will conduct the actual attack along a more southerly axis.*

*At H + 12 minutes, the MRB (-) arrives at the FLOT and attacks through the area where the two motorized rifle platoons are still generating camouflaging smoke with their VEES. Each of the two tank platoons from the attacking force now fires a half volley of grenades. The units that had previously fired their grenades to distract attention fire the rest of their grenades and begin to move forward.*

*At H + 13 minutes, the tanks from the main attacking formation fire the rest of their grenades as they*

Table 3. Total Threat rounds used in example.

No. of Tubes	Type	Total Rounds Available	Total Rounds Used
NA	DM11 Smoke Pots	60	0
18	122-mm SP Howitzers	72 WP 1,296 HE 72 AT	56 666 0
6	120-mm Mortar	24 WP 432 HE	24 360

continue to attack forward. The feint has stalled and is now unobserved. HE rounds are still falling on the objective (Figure 2, below).

The mortar and artillery units start firing an HE/WP mix at H + 15 minutes.

At H + 16 minutes, Threat fire shifts to the rear of the defensive positions to isolate our force.

For a list of total obscurant and artillery assets used by the Threat in this example, see Table 3.

## Threat Defensive Smoke Use

Threat defensive smoke use can be grouped into two broad categories. These are smoke for protection from fire and smoke to disrupt and defeat advancing forces.

### Smoke for Protection

Examples of Threat smoke usage for protection include the following

- To camouflage the maneuvers of their subunits of tanks, infantry, and artillery.
- To conceal engineer activities from our observation.
- To screen replacements of first-echelon units and subunits under conditions of good visibility.
- To camouflage the approach of their subunits for counterattack.

- To ensure flank and maneuver security.
- To mislead our forces on the disposition of second echelons and reserves and planned counterattack directions.
- To conceal the withdrawal of the battle outpost.
- To counter our reconnaissance, intelligence, target acquisition, and weapon guidance and control systems.
- To protect targets from laser designators.
- To blind our observation posts and forward observers.
- To conceal engineer breaching operations.
- To conceal aerial reference points.
- To defeat the light and heat effects of nuclear weapons.

### Smoke to Disrupt and Defeat Advancing Forces

The Threat also will use smoke while in the defense to slow, disrupt, and defeat our advancing forces. Several Threat writings expressed concern over identifying targets set against forest or brush backgrounds. For this reason, the Threat developed techniques involving the use of smoke and illumination rounds to serve as an artificial background. This makes target identification easier. These techniques involve firing mortar and/or artillery smoke rounds 50 to 100 meters beyond our advancing forces. Then they place illumination rounds just

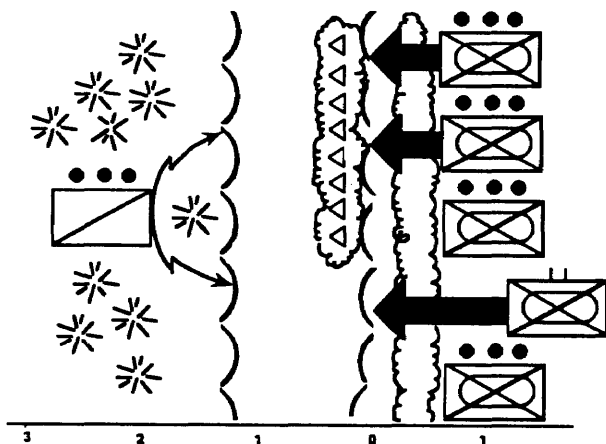

Figure 1. FSE vehicles start the VEES smoke while artillery prepares the objective with HE, thus concealing the movement of the MRB as it prepares to attack through the FSE.

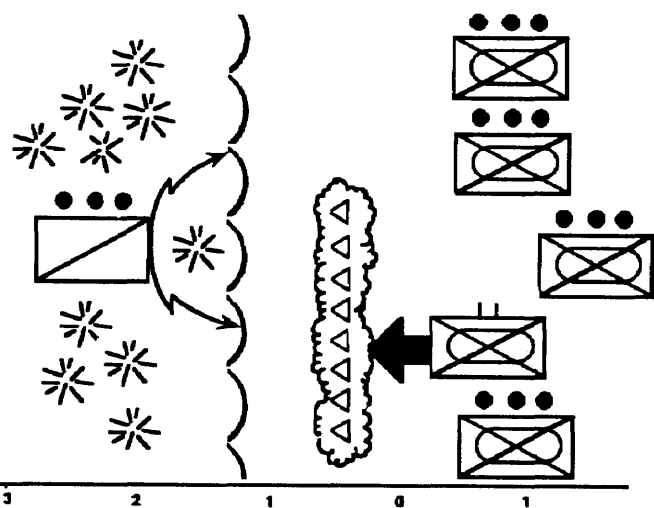

Figure 2. The FSE vehicles stop making smoke, and the MRB emerges from the smoke in position to assault the objective.

beyond the smoke to illuminate the background from the rear. This creates favorable conditions for observation and acquisition.

Also, Threat doctrine states that smoke deprives our units, when shrouded in smoke, of the capability to conduct observation of the field of battle. Smoke will make fire control and navigation more difficult. As a result, our attacking forces can stray off course from the specified directions and get mixed up with each other. There is potential for us to reduce or not aim our fire, creating favorable conditions for Threat second echelons and reserves to deploy, seize the initiative, and counterattack.

### Threat Smoke Example

The best illustration of Threat smoke use in the defense is a Threat hasty defense versus a friendly deliberate attack. In the following scenario, Threat forces have attacked and are well within our territory. Threat forces have already made an unsuccessful attempt to attack from a position in contact.

*The Threat force commander is preparing to conduct an attack from a position in contact. Before he can initiate this attack we attack. Two minutes after our forces begin their preparatory fire, Threat artillery uses counterbattery fire with HE onto our scout platoon.*

*When their forces have identified our axis of advance, they begin to establish an obscuring line, using WP and illumination rounds approximately 150 to 200 meters in front of our FLOT. When our attackers emerge from the smoke, Threat forces engage them with ATGM weapon systems.*

*The Threat will establish a second obscuring line approximately 900 meters in front of our FLOT, using HE and WP fire. Again, ATGM fire will engage our attacking forces when we emerge from the smoke. As our forces reach the point 1,000 meters from the Threat's FLOT, they will engage us with HE munitions from a 122-millimeter multiple rocket launcher.*

## Commander's Considerations

Even the most sophisticated weapon systems are limited by terrain and weather. Prior planning by the S2/G2, S3/G3, and the chemical officer can increase the limitations of enemy systems with man-made obscurants. The commander will have to decide how smoke and obscurants will affect his ability to conduct the direct fire fight. Given the various types of EO devices and the number of visual and bispectral obscurants that will be common on any future battlefield, the answer to this question is not easy. The Soviets may not have thermal imagery sights on their weapon systems. However, other potential adversaries are attempting to acquire or already have the systems. During any future conflict, you must know your enemy. "What?" "When?" "Where?" "How?" and "With how many?" will always be the questions to answer. Other PIRs to determine the effects of obscurants are the—

- EO system capabilities of the enemy force.
- Extent of their employment: whether on reconnaissance systems, direct fire systems, or all systems.
- Smoke delivery capabilities of the enemy force.

- Extent of enemy smoke employment.

- Directed-energy weapon capabilities of the enemy force.

We use smoke and obscurants to attack Threat EO systems and to protect our force. Smoke and obscurants can change the number of effective weapon systems available to either force. Once the commander decides to use smoke and obscurants, the outcome of the battle and the proficiency of his intelligence, operations, and chemical officers will determine the effectiveness of his weapons.

The four examples in Figure 3, on the next page, illustrate how smoke affects the number of enemy weapon systems that can engage the combat battalion. Example 1 depicts the force ratio when smoke is not used. In this example, the standard force ratio is Threat forces 6.4:1 over friendly forces. In examples 2 through 4, the same size force uses equal amounts of smoke and puts it in the same location. However, the force ratio changes in each example based on the relative abilities of opposing weapon systems to see through the smoke and engage targets.

Example 2 shows that the Threat use of smoke degrades the enemy's own force combat power when we have ATGMs with thermal sights (for example, TOW II). TOW II can see and shoot through most smokes. This increases our force ratio (2.5:1) over that depicted in example 1 (1:6.4) by removing all Threat long-range direct fire weapons while not significantly degrading friendly long-range tank main gun (M1) and missile shots (IFV and ITV).

In example 3, we use smoke against a high-technology threat. Our use of smoke degrades the Threat's combat power when we have the TOW II. The force ratios are the same as in example 2. In example 4, we use smoke against a low-technology threat. This eliminates the Threat's ability to fight the direct fire fight since none of the enemy's long-range fire systems can see through smoke. In this case, our force ratio significantly increases (8:1). Friendly forces are able to engage the Threat's entire force.

We could describe an infinite number of combinations of smoke and weapon usage; therefore, com-



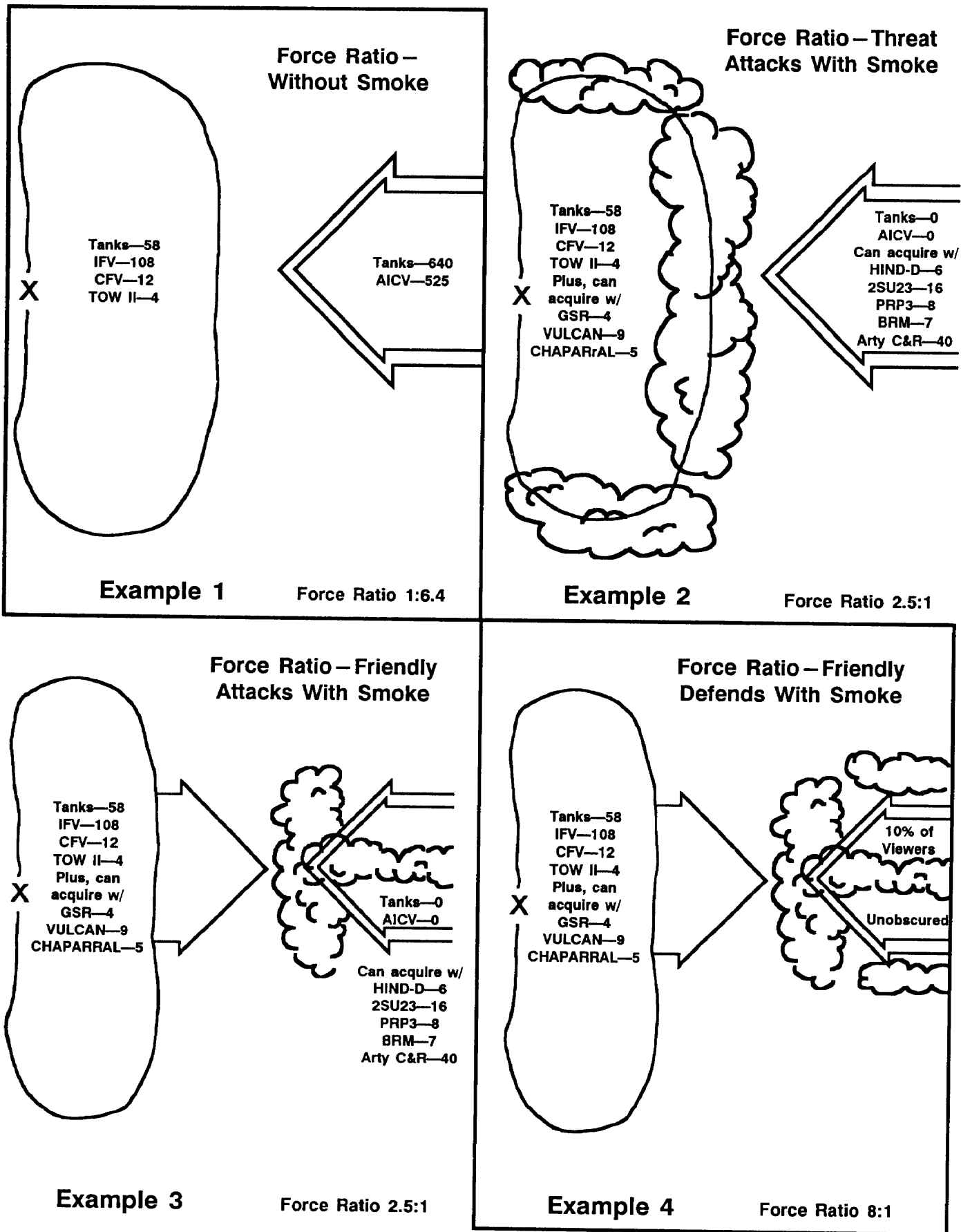

Figure 3. How smoke can change force ratios in the attack and defense.

manders must consider the following principles when using smoke:

- Smoke usage can change the number of effective weapon systems available to either force.
- Smoke effectiveness is directly related to the relative ability of

Threat direct fire systems to see and shoot through smoke.

- Employing smoke improperly can degrade friendly combat potential. When in doubt, employ smoke only when you can see and fire through it. Know your ability and that of

your enemy to see and fire through smoke. Plan the battle accordingly and never leave smoke employment to chance.

## US Countermeasures to Threat Use of Smoke

Threat smoke and obscurant use has the potential for significantly degrading both our defensive and offensive operations. In general, there are two options available to counter enemy smoke use: Move to alternate positions on the battlefield to continue unimpaired operations, or use EO devices that allow operations to continue under smoke.

Our forces must first understand Threat doctrine regarding use of smoke and obscurants to anticipate when and where the Threat will employ them on the battlefield. Next, our commanders must train their units to operate in periods of limited visibility where target acquisition, navigation, and command and control are confusing and difficult. Finally, we must train and use tactics, techniques, and procedures that overcome or minimize the effectiveness of Threat smoke and obscurant usage.

### Obstacles

Obstacles placed along the enemy's most likely avenue of advance can slow them, disrupting their timetables. Preplanned fire on these positions can be an effective means of engaging the enemy even in dense concentrations of smoke.

Acquisition devices that are less sensitive to smoke and obscurants can acquire the enemy at choke points and/or barriers and then direct engagement by direct and indirect fire. Obstacles can delay one element of the attacking force, drawing an adjacent element into an engagement area, unable to receive supporting fire. Separation of forces may also occur due to the enemy's own use of smoke.

### Dispersion

Dispersing our forces laterally and in depth places a greater burden on attacking fire. Combining dispersion with rigorous counterreconnaissance measures forces the Threat to expend more resources and take greater risks in conducting attacks. The more dispersed you are, the more difficult and costly it is for the Threat to bring blinding smoke fire on your positions. Additionally, dispersing in depth aids in obtaining flanking fire where the Threat smoke is much less concentrated.

### Deception

Tactical deception can cause the Threat to ineffectively use smoke assets. For example, an effective ruse might cause the enemy to expend greater resources in attempting to blind friendly gunners and camouflage tank movement. This would reduce overall smoke effectiveness. Using deception means may also cause the enemy to attack in the wrong direction and become silhouetted against their own smoke, allowing us to effectively engage their force without smoke degrading our line of sight.

### Friendly Countersmoke

Friendly forces can use smoke and obscurants to counter enemy use of smoke as control measures or phase lines. Friendly visual obscurants can flood the area between friendly defensive positions and enemy smoke lines to disorient the enemy and deceive them as to the actual battle positions. At the same time, friendly units can engage the enemy

using thermal imagers and direct fire weapon systems.

### Engagement of Enemy Forces in March Formation

The Threat does not plan as much smoke to protect the force while they are still behind the FLOT. If we engage enemy march formations, less enemy smoke use should enhance our fire.

### Limited Visibility Positions

Threat doctrine calls for the Threat to lift all smoke when they come within 1,000 meters of their objective. Using alternate positions forward of your main defense will cause attrition in their attacking force and disrupt their timetables, creating surprise and confusion when they emerge from their final smoke screen. However, the use of any alternate positions increases the need for countersurveillance and counterreconnaissance measures.

Occupation of reverse slope positions coupled with alternate or dummy positions on the forward slope can cause the enemy to waste artillery assets and give friendly defenders more time to react when enemy attackers emerge from their own smoke.

### Stay-Behind Forces

Stay-behind forces using nonlinear tactics can engage an enemy from their flanks and rear where they are often unobscured.

## **Positioning of Observers and Observation Devices**

Position forward observers, warning systems, and ground/vehicle laser locator designators (G/VLLDs) where they are less likely to encounter obscuration during the battle. The highest point of a battle position normally offers the best lines of sight for laser designators. However, because of the vulnerability of these G/VLLDs to smoke and obscurants, commanders should attempt to avoid blinding by placing these devices on the flanks of a battle position.

## **Targeting of Enemy Smoke Assets**

In addition to passive countermeasures, we can also take active steps to reduce the obscurant threat. Using IPB with a thorough understanding of how the enemy employs smoke assets, we can determine the location of those smoke assets. Once located, enemy artillery and smoke generator units are extremely vulnerable to friendly fire.

## **Ground Surveillance Radar**

Employ ground surveillance radar (GSR) with maneuver elements to direct, identify, and locate targets in smoke. Ensure our own obscurant operations do not mask GSRs with millimeter wave obscurants and that GSRs can continue to provide targeting data to commanders when smoke obscures other surveillance means.

## **Use of Threat Smoke to Conceal Our Maneuver**

When the Threat uses smoke between their forces and ours, we can exploit the fact that they are as likely to be unable to see through it as we. We can use their smoke to aid in obtaining surprise for our own attack or counterattack.

## **Use of Friendly Aviation**

Use friendly aviation assets to identify gaps in smoke coverage. Target hand-off procedures must facilitate air and ground target engagement.

## **Preplanned Disengagements**

Execute preplanned disengagement based on remote signal devices rather than visual cues. Use a thorough IPB to establish the key event for disengagement on your decision support templates.

## **Air Defense Positions**

Position air defense assets where they obtain the most benefit from enemy smoke. Emplace systems requiring visual target acquisition (for example, Vulcan and Stinger) on high ground clear of the smoke. Use them to look over the smoke and engage low-flying helicopters and aircraft that silhouette against the smoke. Emplace air defense systems using thermal or millimeter wave acquisition in the smoke to mask missile launch points.

## Offensive Operations

The offense is characterized by violence, concentration of friendly forces, disruption of hostile forces, and rapid transitions between different types of operations. Smoke

and obscurant use multiplies the commander's ability to project combat power at the critical time and place to defeat the enemy. Smoke and obscurant use will support any

type of offensive operation at any level because smoke generally favors the attacker.

## Historical Perspective

The most recent and perhaps most significant example of smoke in a combat multiplier role occurred during the 1973 Arab-Israeli War. On 6 October 1973, at 1400 hours, Egyptian forces attacked

prepared Israeli positions defending the west bank of the Suez Canal. The Egyptians initiated the attack by deploying 200 attack aircraft into the Sinai to destroy Israeli com-

munications centers, airstrips, and artillery positions (Figure 4). Within moments, Egyptian artillery opened up with a massive barrage of high-explosive munitions and blinding smoke. The Egyptians intended to

degrade the ability of the Israelis to engage targets and adjust artillery fire with that blinding smoke. It accomplished its purpose with devastating results; it induced a feeling of total isolation among defending Israeli units. The fear caused by the addition of yellow smoke to the artillery preparation amplified the psychological effects of isolation. The defenders believed they were being gassed.

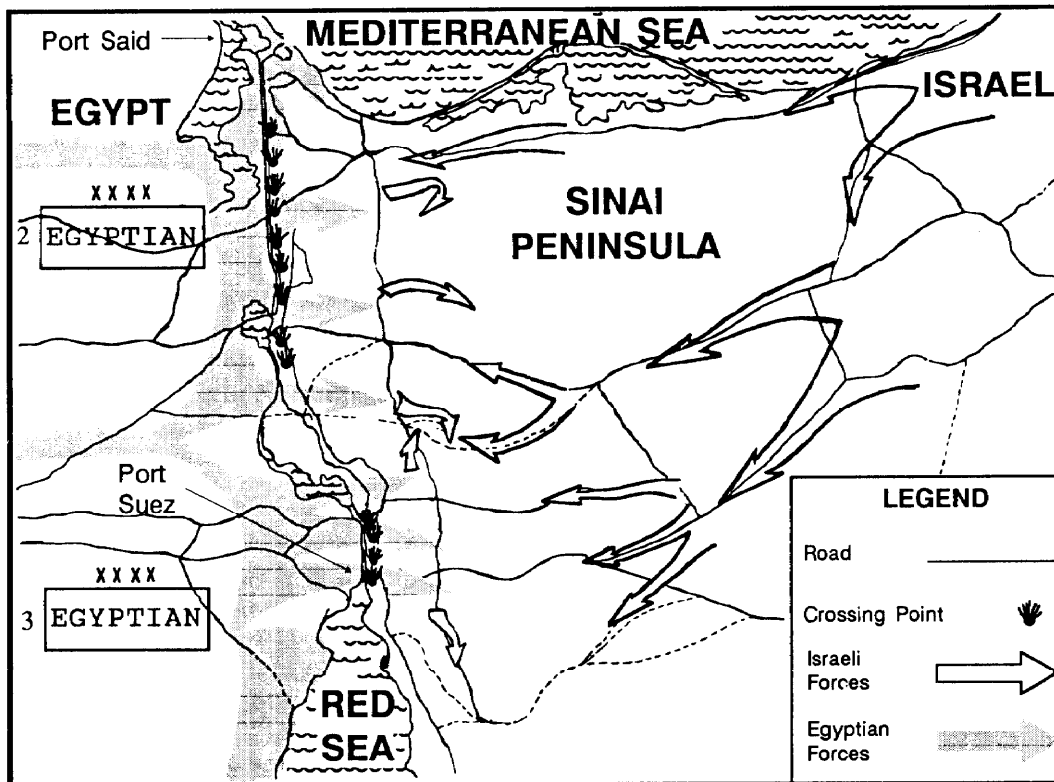

Figure 4. Egyptian assault crossing under smoke at the Bar-Lev Line in 1973. The Egyptian force, indicated by the darker arrows, crossed at mid-day under heavy smoke, and surprised the Israeli forces.

Minutes later Egyptian armored and artillery assets began to deploy forward to firing positions on their side of the canal. These units engaged the Bar-Lev strongpoints with direct fire while infantry units conducted a forced crossing in dinghies under the cover of canister-generated smoke. Air-mobile operations placed commando units 10 miles into the rear to disrupt reinforcing echelons. Egyptian engineer units emplaced bridges over the canal. Smoke from artillery, canister, and smoke generator assets supported the engineer effort.

The National Training Center (NTC) is an area where smoke training is possible on a large force-on-force scale. MG E. S. Leland, former commander of the NTC, stated, "Smoke is a far more significant battlefield factor than I used to believe. It simply must be a major planning consideration in terms of both friendly employment and reaction to enemy use."

Key insights from the NTC for the offense include the following:

- Smoke favors the attacker.
- Smoke tightens attack formations.
- We must capitalize on thermal imager capability.
- We must plan command and control without visual cues.
- Training and rehearsal are the keys to success.

Smoke and obscurants integrated throughout the offensive framework provide major contributions to combat power in deep, close, and rear operations. In the offense, use smoke to—

- Support maneuver by—
    - Concealing maneuvering forces from enemy observation.
    - Providing tactical surprise and allowing the commander to set the terms of combat.
    - Allowing the commander to mass forces unobserved.
- Defeating enemy surveillance efforts.
- Supporting the deception plan.

These actions demonstrated the tremendous impact of smoke when synchronized with a combined arms assault. Within the first 24 hours of the attack, the Egyptians accomplished the almost impossible: They had moved five divisions, 100,000 men, 1,020 tanks, and 13,500 vehicles across the canal and established a bridgehead six miles into the Sinai. The Israeli forces lost 150 tanks, almost one-tenth of their total in the Sinai. The blinding smoke placed on the Bar-Lev strongpoints effectively reduced the

Israeli ability to acquire targets and spot for attack aircraft.

The Egyptian Army was eventually driven back and sustained considerable losses. Nevertheless, their forced crossing of what the Israelis believed to be the largest tank ditch in the world was a complete success. The effect that smoke played in that operation was significant. While the crossing may have been effective without smoke, the Egyptian forces could have sustained far greater casualties, and the crossing could have taken far longer to complete without the cover of smoke.

## Tactics

- Provide additional firepower by—
  - Changing friendly to enemy force ratios by using thermal imagers and millimeter wave acquisition devices such as radars to see through visual smokes and using smoke to isolate defending and second-echelon forces.
  - Defeating enemy counterreconnaissance efforts.
  - Enhancing friendly target acquisition efforts by silhouetting enemy vehicles with smoke and using smoke and obscurants we can see through but the enemy cannot. Disrupting enemy maneuver and reinforcement.
  - Disrupting the enemy's ability to communicate.
- Protect the force by—
  - Reducing friendly force vulnerability by concealing support forces from enemy observation and defeating enemy reconnaissance efforts.
  - Concealing obstacle breaching.
  - Defeating enemy weapons by defeating enemy target acquisition efforts, defeating enemy guidance systems, and negating standoff capability of enemy long-range direct fire weapons.
  - Degrading or defeating enemy directed-energy weapons.

## Use

Smoke and obscurant use in the offense requires careful planning and execution to prevent interference with movement, assault operations, or target acquisition; to retain the element of surprise; and to avoid silhouetting or drawing undue attention to friendly forces.

Smoke use is not without risks. Our use of smoke must increase friendly force survivability without seriously degrading operational capabilities. It must decrease Threat force command, control, communications, and intelligence gathering capabilities (C3I).

In addition to the general employment techniques detailed in Chapter 1, techniques to minimize interference in the offense include the following:

- **Use covered and concealed maneuver techniques.** Assume the enemy can see through the smoke. Do not take unnecessary risks with the force.
- **Time smoke delivery with decision points.** Conduct a thorough IPB and time your use of smoke to key decision points in your tactical plan; for example, "When we reach Hill 285, we will call for A Battery to fire smoke and HE onto target XY1007 and sustain that fire to obscure enemy observa-

tion of our flanking of Objective White."

- **Use unobscured weapons to overwatch.** The overmatching elements should have target acquisition devices such as thermal imagers that can see through our own smoke and engage the enemy. This prevents surprise and enhances the ability to suppress enemy fire during the assault.

- **Do not let your own smoke silhouette your forces.** Never overrun your smoke cloud prior to the final assault. "Walk smoke in" towards enemy positions wherever possible. This ensures your forces remain concealed and confuses the enemy as to your exact location and intent.

- **Plan to engage through or around the smoke.** Plan to use weapon systems that can acquire and fire through the smoke. Plan limited visibility positions for those systems that smoke degrades (for example, position target acquisition assets on flanks or above smoke).

- **Plan for enemy countermeasures.** Enemy forces will counter your smoke use. Plan to intensify your counterreconnaissance and air defense efforts. The enemy may use countersmoke to confuse your command and control, so avoid reliance on visual signals. The enemy will increase use of indirect fire weapons when direct fire target acquisition is ineffective. Therefore, plan artillery counterbattery and countersmoke fire after crossing the line of departure/line of crossing (LD/LC).

- **Plan for additional maneuver time under smoke.** Smoke slows maneuver. Base the planning factor on METT-T and the proficiency of your unit to operate under smoke as shown in previous combat (or training) operations.

- **Verify enemy locations (responsibility of reconnaissance).** The enemy can use both our smoke and theirs to conceal movement to alternate positions or to break contact. Aggressive reconnaissance before and during the engagement will allow you to shoot and remain in contact.

## Goal

The main focus of smoke in the offense is to defeat enemy RSTA efforts, conceal maneuver and support forces, and contribute to tactical deception operations. Our intent is to deny the enemy information about the disposition and composition of our forces, which provides surprise and security. It also allows the commander the flexibility to mass the forces required to conduct attacks. The next section presents the tactics for using smoke in offensive operations. Appendix A contains tactical decision aids for determining which smoke delivery means to use against the specific smoke targets covered by these tactics.

## Phases

The phases of the offense are preparation, attack, exploitation, and pursuit.

### Preparation

The preparation phase of offensive operations involves the concentration of attacking forces and associated support elements into contact with the enemy.

The overriding imperative in a movement to contact is initiative.

Use smoke to –

- Conceal movement of maneuver and support forces, allowing the commander to mass forces unobserved.
- Provide tactical surprise, allowing the commander to seize the initiative and set the terms of combat.
- Defeat enemy reconnaissance and counterreconnaissance efforts.
- Conceal obstacle breaching or crossing.

Smoke employment tactics in the preparation phase are the following:

- **Screening smoke.** Use screening smoke to conceal maneuver and obstacle breaching or crossing. Use smoke in the main body area and along the flanks to conceal movement. You must carefully control the smoke to prevent silhouetting

your units. Begin making smoke prior to crossing the line of departure to confuse the enemy as to the actual location and size of the force.

- **Protecting smoke.** Use protecting smoke as required to defeat enemy ATGMs and air defense systems.

- **Obscuring smoke.** Use obscuring smoke to defeat enemy reconnaissance and counterreconnaissance efforts. Use projected smoke means to deliver smoke mixed with high-explosive rounds before the enemy can pinpoint your units. Plan obscuring fire based on decision points for the enemy, isolating and confusing their reconnaissance forces.

- **Marking smoke.** Use smoke to mark enemy targets for rapid destruction or to reduce the potential for firing on friendly forces.

- **Smoke for deception.** Use this smoke to draw attention to areas of little or no importance. Create large-area smoke away from the main body. Consider using smoke mixed with high-explosive rounds to conduct preparatory fire on dummy objectives.

Figure 5, on the next page, illustrates smoke employment in the preparation phase.

### Attack

A hasty attack will normally immediately follow a movement to contact. If the contact reveals an overwhelmingly superior enemy force, or our hasty attack is unable to either outflank or overcome the enemy defense, we will conduct a deliberate attack. In the attack phase, use smoke to—

- Provide tactical surprise, allowing the commander to seize the initiative early.

- Conceal movement of maneuver and support forces, allowing the commander to mass forces unobserved. Smoke must provide the commander with the ability to concentrate the maximum possible shock and violence against the enemy.

- Ruin the enemy commander's synchronization.

- Conceal obstacle breaching or crossing.
- Defeat enemy target acquisition, weapon guidance, and directed-energy weapon systems.

The overriding imperative in hasty attacks is agility. Therefore, smoke use in a hasty attack must assist the commander to fix and contain the enemy, deploy into combat formations, and maneuver additional forces to the flank and rear where the enemy is destroyed by fire or assault.

Smoke employment tactics in a hasty attack include obscuring smoke, screening smoke, marking smoke, protecting smoke, and deceptive smoke:

- Obscuring smoke. Use obscuring smoke to isolate the objective, defeat enemy target acquisition and guidance systems, and defeat reconnaissance and counterreconnaissance efforts. Use projected smoke means to deliver smoke mixed with high-explosive rounds in front of the objective; between enemy formations; and on identified forward observer, ATGM, and tank unit positions before the enemy can pinpoint your units as targets. Using projected smoke as

countersmoke and to isolate the objective can significantly interfere with the enemy commander's synchronization.

- Screening smoke. Use screening smoke to conceal maneuver as you bypass small pockets of resistance and breach obstacles. Use it also along the flanks to protect the force and in the rear to conceal disposition and composi-

tion of reserves. Use self-defense and generated-smoke means to deliver smoke across danger areas and to the flanks of the force to limit enemy observation and engagement.

- Marking smoke. The tactics are the same as in the preparation phase.
- Protecting smoke. The tactics are the same as in the preparation phase.
- Deceptive smoke. The tactics are the same as in the preparation phase.

The overriding imperative for the **deliberate attack** is synchronization. Therefore, smoke use in the deliberate attack must assist the commander to fix and maneuver against the enemy and prevent the enemy from breaking contact. It must also force penetration of the enemy's defense and prevent reinforcement or counterattack by enemy reserves or second-echelon forces. Smoke employment tactics in a deliberate attack have the same

names as for the preparation phase, but read on.

- Obscuring smoke. Use obscuring smoke to isolate the objective and complement countermobility efforts. Use it also to defeat enemy target acquisition and guidance systems and defeat reconnaissance and counterreconnaissance efforts. Use projected smoke means to deliver smoke mixed with high-explosive rounds in front of the objective, between enemy formations, on identified forward observers, and on ATGM and tank unit positions before the enemy can pinpoint your units as targets. Use smoke mixed with scatterable mines for countermobility behind enemy positions. Use it also between the enemy first-echelon, reserve, and second-echelon forces. The critical activity in planning obscuring fire in the deliberate attack is synchronization of all direct fire, fire support, smoke support, and engineer assets to create maximum combat power.

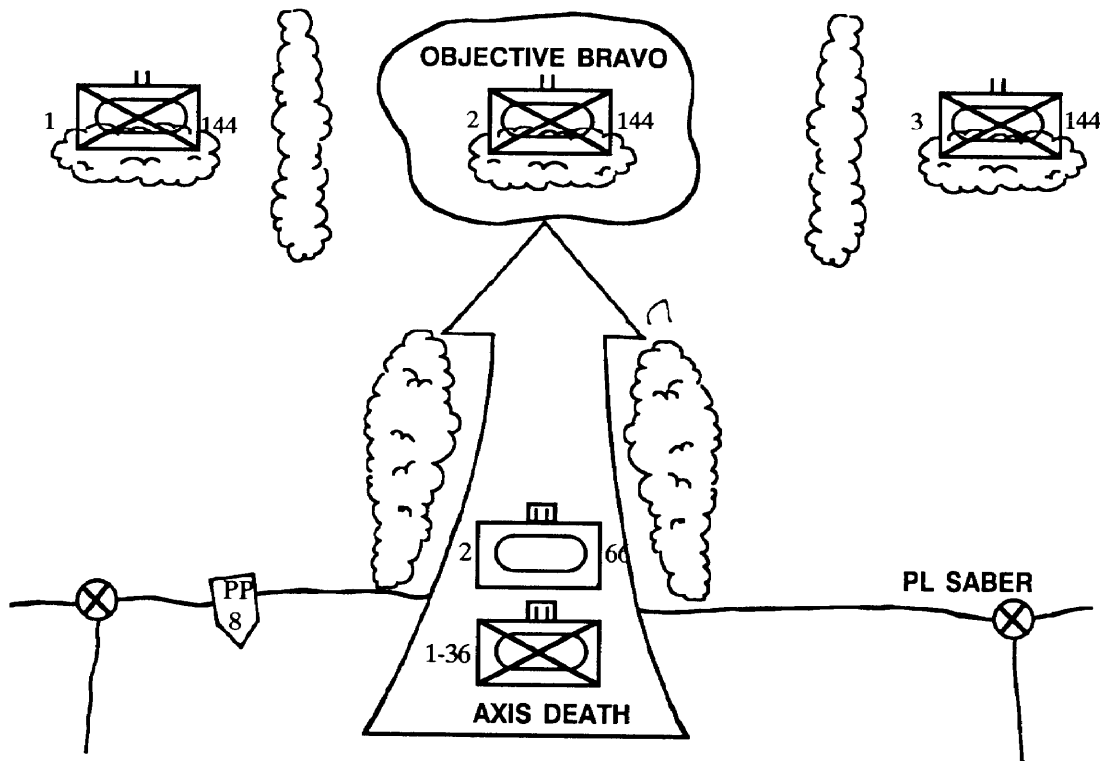

Figure 5. This example of employment in the preparation phase uses mechanized smoke units on the flanks of Axis Death to protect the force. Projected smoke and HE fired at TAI's blind the enemy recon assets and isolate enemy formations from each other. By suppressing enemy RSTA efforts, the brigade can close on the enemy without significant losses.

- Screening smoke. Use screening smoke to conceal maneuver as you cross the line of contact, bypass small pockets of resistance, or bypass or breach obstacles; along the flanks to protect the force; and in the rear to conceal disposition and composition of reserves. Use large-area generated smoke to conceal passage of lines and confuse the enemy concerning the disposition and composition of your force. Reconnaissance of enemy obstacles is critical to ensure timely employment of large-area smoke to conceal breaching or crossing of obstacles. Use self-defense and generated-smoke means to deliver smoke across danger areas and to the flanks of the force to limit enemy observation and engagement.
- Marking smoke. Use marking smoke to mark enemy targets for rapid destruction or to reduce the potential for firing on friendly forces. Use projected smoke means such as helicopter rockets to mark close and deep targets for engagement by close air support aircraft.
- Protecting smoke. If the enemy has known or suspected directed-energy weapon capability, concealing your force in a blanket of oil smoke will attenuate some of the energy. In the far term, using large-area projected smoke containing millimeter wave obscurants directly on the enemy positions will reduce our vulnerability to directed-energy weapons.
- Smoke for deception. Use supporting smoke to draw attention away from the main effort to areas of little or no importance. Use generated-smoke means (in a deliberate attack, the best means may be smoke pots and generators) to create smoke away from the main body. The deception story must be integrated into the overall tactical plan for smoke use to be effective.

### Exploitation

Commanders should plan to follow every attack by bold exploitation to keep the enemy under

pressure, compound their disorganization, and erode their will to resist. The overriding imperative in exploitation is depth. In the exploitation phase, use smoke to—

- Ruin the enemy commander's synchronization.
- Isolate enemy forces, allowing the commander to keep the enemy in contact and under pressure.
- Conceal movement of maneuver and support forces, allowing the commander to protect logistical units and convoys required to sustain the momentum of the exploiting force.
- Defeat enemy target acquisition, weapon guidance, and directed-energy weapon systems. This is particularly important as the exploitation force bypasses or contains small groups of enemy forces.

Smoke employment tactics in the exploitation phase use the same five types of smoke as follows:

- Obscuring smoke. Use obscuring smoke to complement counter-mobility efforts, defeat enemy target acquisition and guidance systems, and isolate enemy forces for piecemeal destruction. Use projected means to deliver smoke mixed with high-explosive rounds onto targets between enemy formations, onto enemy units as they attempt to regroup, and in front of enemy strongpoints as you bypass them. Use smoke mixed with scatterable mines behind moving enemy formations to impede their ability to break contact and to compound their disorganization.
- Screening smoke. Use this smoke to conceal maneuver and support forces and defeat enemy target acquisition and guidance systems. As protection of supplies and support units is essential to maintain the rapid tempo of the exploitation, priority of effort for smoke assets must go to sustainment activities. Use generated-smoke means to deliver smoke onto key logistics activities and to protect convoys. Use self-defense and generated-smoke means to conceal maneuver units as they bypass or harass enemy forces.

- Marking smoke. Use marking smoke to mark targets for destruction, identify bypass routes, and signal for battlefield activities. Use projected smoke means to deliver smoke onto identified enemy strongpoints or larger formations and to signal forces to consolidate on a particular objective or rally point. As exploitation force commanders rely heavily on air cavalry units for reconnaissance, helicopter-delivered smoke rockets will provide the best delivery system. Use generated-smoke means to mark bypass routes (for example, scouts could drop smoke pots at 100- to 200-meter intervals along a bypass route).
- Protecting smoke. The risk of nuclear weapon use increases when conventional means are ineffective in stopping our advance. If the enemy has known or suspected nuclear or directed-energy weapon capability, concealing your logistics activities in oil smokes may attenuate some of the energy.
- Supporting smoke for tactical deception. Use supporting smoke to keep the enemy off-balance and to draw attention away from critical sustainment activities. Use generated-smoke means to deliver smoke to multiple locations to the rear of the exploitation force to force the enemy to expend resources to target logistical activities.

### Pursuit

As the enemy becomes demoralized and their formations begin to disintegrate, exploitation may develop into pursuit. Commanders attempt to annihilate the enemy force using a direct pressure force that keeps the enemy units in flight and an encircling force to envelop, cut off, and destroy or capture the fleeing enemy force. In the pursuit, use smoke to—

- Ruin the enemy commander's synchronization, denying the enemy time to reorganize a cohesive defense. If the enemy is able to establish a perimeter, smoke must help to defeat enemy target acquisition.



tion, weapon guidance, and directed-energy weapon systems.

- Isolate enemy forces, allowing the commander to keep the enemy in contact and under pressure.
- Conceal movement of maneuver forces, allowing the commander to envelop the enemy force.

Smoke employment tactics in the pursuit include the following applications of the five basic smoke types:

- Obscuring smoke. The tactics are the same as in the exploitation phase. Additionally, use generated smoke from the direct pressure

force towards the enemy to obscure their observation while giving the encircling force freedom of maneuver. When in place, the encircling force could use generated smoke towards the enemy to obscure our forces, silhouette the enemy, and generally increase the enemy commander's synchronization problems.

- Screening smoke. Use screening smoke to conceal maneuver forces and defeat enemy target acquisition and guidance systems. Since the encircling force generally advances on parallel routes, screening smoke along the flanks of the encircling

force can conceal their maneuver. However, since smoke draws attention, you may risk losing the element of surprise. Use self-defense and generated-smoke means to conceal maneuver units as they bypass or attack enemy forces.

- Marking smoke. The tactics are the same as in the exploitation phase.
- Protecting smoke. The tactics are the same as in the exploitation phase.
- Smoke for deception. Use this smoke to keep the enemy off-balance and to support hasty at-

tacks if the enemy is able to establish a perimeter. Use smoke generators to deliver smoke to multiple locations creating false passage points and to draw attention away from the main effort.

Figure 6, below, illustrates smoke employment in the exploitation and pursuit phases.

### Attack Scenario

The following scenario illustrates possible smoke employment options in the offense, from the preparation through the pursuit phases. It depicts a mechanized infantry brigade conducting the movement to contact. The brigade is the 2d Brigade, 54th Infantry Division (M).

Smoke delivery means include the direct support artillery battalion, battalion mortars, smoke generator platoon, VEES, smoke pots, smoke grenades, and aviation assets on-call. Field expedient smoke delivery means include smoke pots strapped to armored vehicles with electrical ignition wires running inside the vehicle.

2d Brigade will conduct a movement to contact commencing at H-hour today. The commander's intent is

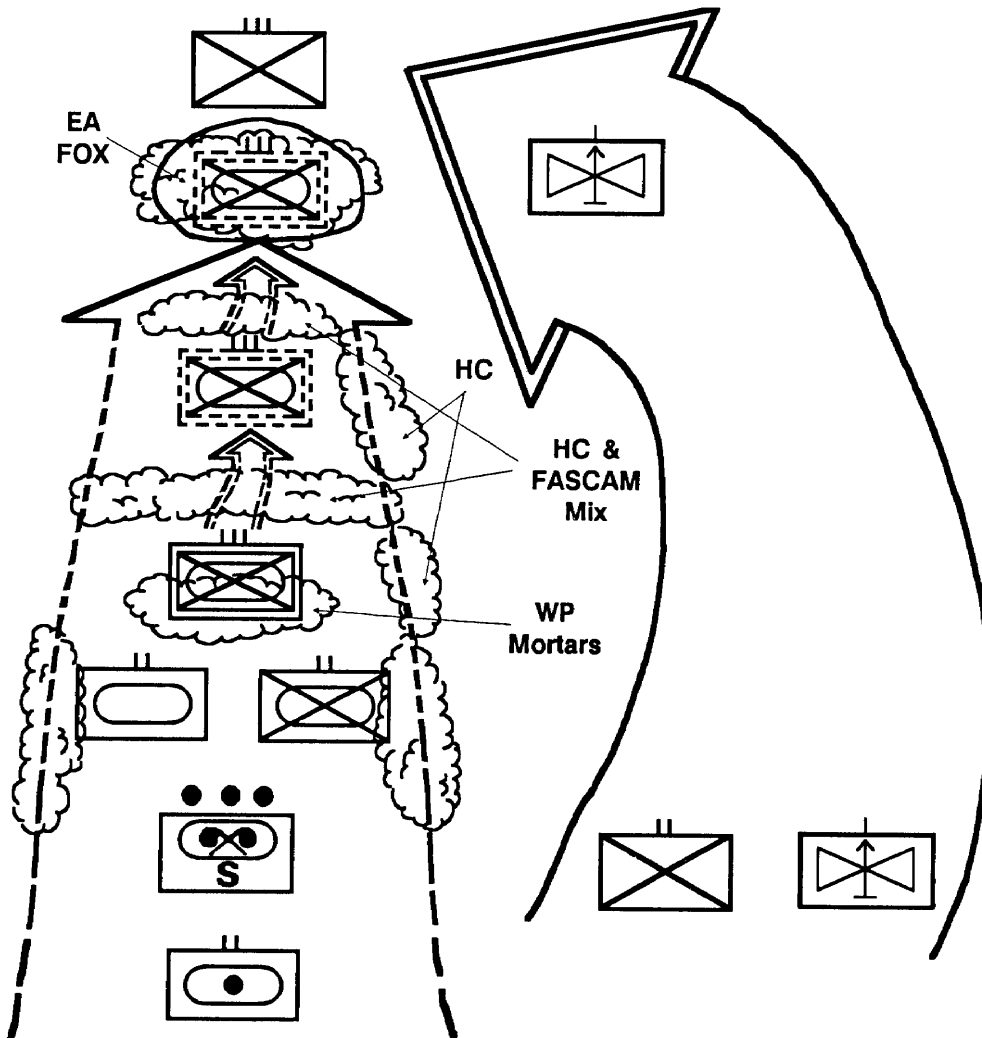

Figure 6. In this pursuit phase example, we are using FASCAM at choke points behind the enemy formation. As the enemy nears the choke points, artillery-delivered HC smoke further delays and complicates enemy command and control. Our lead task force in the direct-pressure force mixes HE and WP on the enemy formation, delaying it. The artillery fires HC smoke on the flanks to mark the flanks and to protect the movement of the encircling force. As the enemy emerges from the smoke in EA Fox, they are silhouetted against it and engaged by our direct fire weapons.

to reestablish contact with the enemy, seize the brigade objective, and exploit any success onto the division objective. The brigade objective is Objective Fox. The brigade's follow-on objective is Objective Jack. The division objective is Objective Midas some 40 kilometers beyond the line of departure.

Intelligence indicates that the enemy is the 1st Guard Motorized Rifle Division, 2d Combined Arms Army, which relieved another motorized rifle division and is conducting a meeting engagement from the march. The enemy is marching by regiments, with three regiments in front and a combined arms reserve instead of a second echelon. Terrain is fairly open to the west of Hill 268 but is restricted to the east of Hill 352. The enemy has excellent observation and fields of fire from both hills. Figure 3-6 illustrates the disposition of forces as of H-1 hour.

At H - 24 hours, the commander issues the restated mission and his planning guidance. The brigade chemical officer, S2, and FSO go to the intelligence cell and begin target development.

The brigade chemical officer has completed his estimate at H - 18 hours and provides a draft target list to the FSO. While the brigade chemical officer briefs the commander, the brigade chemical NCO continues smoke target analysis in coordination with the smoke platoon leader.

At H - 15 hours, the brigade chemical officer, FSO, and smoke platoon leader finalize the smoke support plan. This includes a draft smoke support annex to the brigade OPORD.

#### Preparation Phase (Movement to Contact)

Prior to H-hour the security force and flank security elements prepare expedient smoke devices using smoke pots strapped onto their vehicles. The fire support plan includes quick smoke to isolate the enemy combat reconnaissance patrols (CRPs), so WP and HC smoke ammunition is pre-positioned forward of the artillery battalion in the security force area.

The fire support plan also calls for aviation assets to use smoke rockets to mark the gaps between the enemy CRPs and FSEs. The S3 (air) has coordinated for the attack helicopter squadron to carry extra WP rockets in their first two sorties. The smoke platoon initially travels with the main body and has on-board capability to make smoke for 70 to 140 minutes.

At H-hour, our forces cross the line of departure.

Thirty minutes later, aviation reconnaissance sights the lead elements of the enemy CRP. When the CRP is within 3,000 meters of the security force, the artillery battalion fires HE and smoke (HC) in front of each CRP.

At H + 35 minutes, the security force sights the CRP through the smoke using thermal imagers. The security force then attempts to fix the CRP by engaging it with direct fire weapons through the smoke.

At H + 36 minutes, the security force will also locate and mark bypass routes. The security force ignites smoke pots and drops them off at 200-meter intervals to mark and conceal the bypass.

The smoke platoon moves toward the LD at H + 36 minutes. NOTE: The smoke platoon should always remain behind the security force.

At H + 38 minutes, the aviation reconnaissance and security force sight the enemy FSE. The FSE is moving forward to establish the FLOT along the screen line of the CRP.

At H + 39 minutes, the maneuver battalion mortars begin to fire HE and WP on top of and in between the CRPs. The artillery battalion shifts fire to the area between the FSEs and CRPs, obscuring with a mix of HE and HC.

The smoke generator platoon begins to make smoke at H + 40 minutes at the LD. In addition, the flank security force on the eastern flank ignites and dumps its smoke pots within 500 meters of the LD.

At H + 40 minutes, the security force combat vehicles initiate screening smoke with their VEES. The ar-

tillery and mortar units increase their rate of fire.

At H + 45 minutes, the main body crosses the LD. The main body maneuvers to the west of the smoke along the bypass route (Figure 7, on the next page).

#### Attack Phase

The movement to contact has developed into an actual engagement. The commander seizes the initiative and orders the brigade to attack toward Objective Fox. The main attack is in the west along Axis Andy. The supporting attack is in the east along Axis Tony. The brigade will consolidate on the objective and continue the attack towards the division objective.

At H + 46 minutes, the artillery shifts fire from the area between the CRP and FSE to the area between the FSE and advanced guard (AG), obscuring the target with a mixture of HE and HC. Also, the mortars shift fire from the CRP to between the CRP and FSE, obscuring with a mixture of HE and WP.

When the main attack has cleared the LD, the security force elements in the west turn off their VEES. At the same time the supporting attack force engages the enemy FSE and AG with flanking fire.

At H + 50 minutes, the artillery shifts fire from the area between the FSE and AG to the area between the AG and the main body in the west, and onto the objective in the east. The artillery continues to fire a mix of HE and HC.

Also at H + 50 minutes, the mortars shift fire from the area between the CRP and FSE to the area between the FSE and AG, obscuring with a mix of HE and WP.

At the same time, the smoke platoon stops making smoke. This will ensure the objective itself is unobscured during the assault.

The main attack force is in position to make the assault on the objective at H + 55 minutes. The artillery shifts fire to the regimental main body beyond the objective, now firing only HE. The mortars shift fire onto the AG in the center and in the west,

obscuring and isolating them with HE and WP mix.

At H + 1 hour, the main attack force assaults the objective. Artillery and mortars continue to fire on the enemy main body, isolating the objective from external Support.

**Exploitation Phase**

The enemy resistance is crumbling. 2d Brigade has significantly disrupted the enemy's synchronization and has the initiative. Upon securing the brigade objective, the brigade rapidly consolidates and the commander orders them to continue the attack. The brigade's follow-on objective is to secure Objective Jack and destroy the remnants of the enemy division artillery group (DAG). The main attack is in the east along Axis Stef, with the supporting attack in the center along Axis Gay.

At H + 1.25 hours, the mortars begin to fire on the remaining regimental main bodies, obscuring them with a mixture of HE and HC.

At the same time, the artillery begins to fire scatterable mines and HE and HC mix into the area behind the first echelon regiments. This isolates the first echelon from the combined arms reserve and delays their retreat.

At H + 1.5 hours, the smoke platoon begins to make smoke in the west of the sector to isolate the remnants of the easternmost first-echelon regiments from the other first-echelon regiment. This further disrupts the enemy commander's synchronization, command, and control.

The main and supporting attack forces begun moving towards Objective Jack, keeping the enemy under pressure. They will bypass any enemy

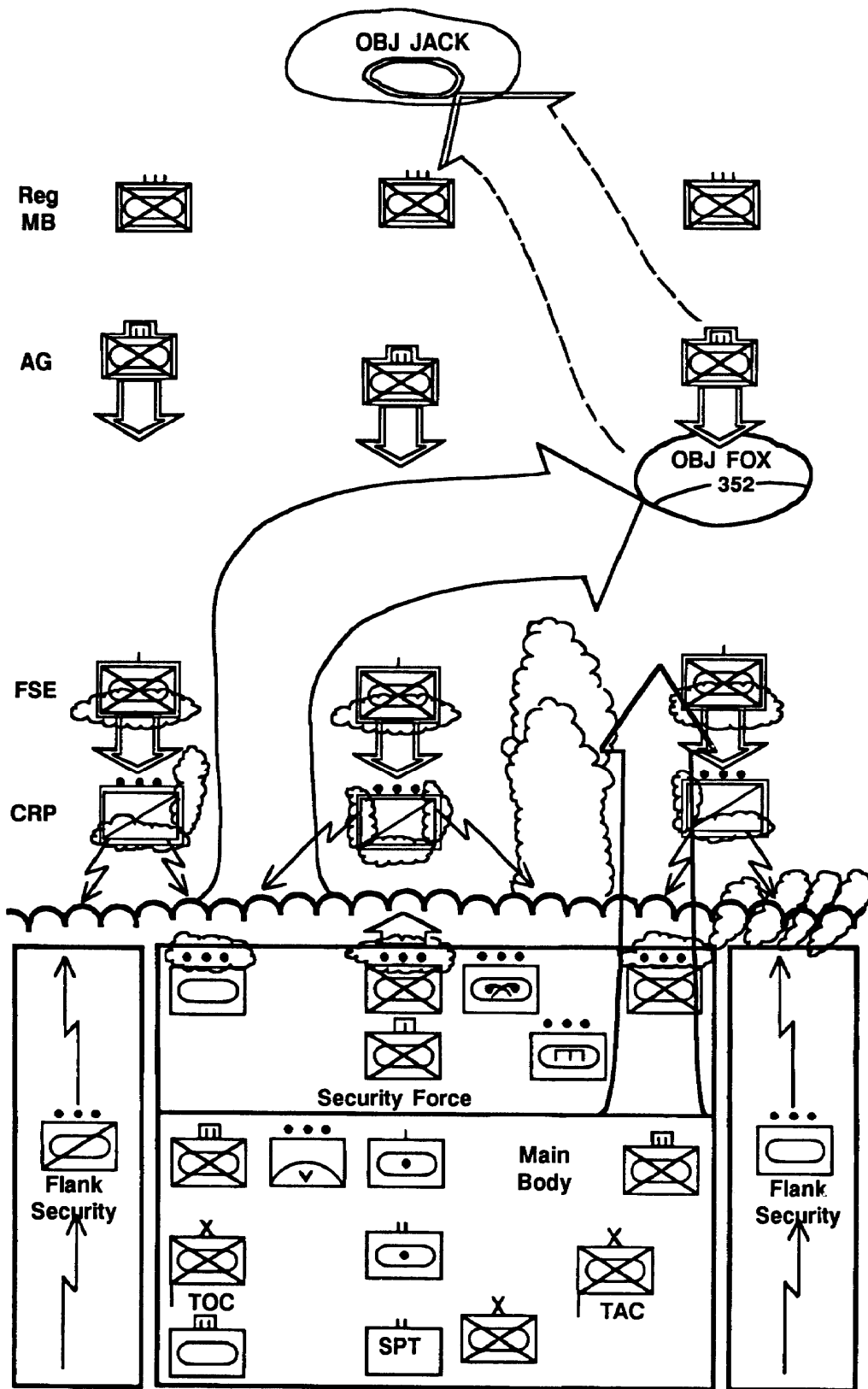

Figure 7. In this attack scenario, we are using the mechanized smoke platoon to produce a large-area smoke cloud to isolate enemy regiments in the east from each other. The security force vehicles use their VEESs to conceal the movement of the main body behind the LD/LC. Projected smoke, fired at TAIs and known enemy positions, obscures enemy RSTA and protects the force as we begin to cross the LD/LC.

forces they encounter, with the brigade follow-on forces containing and destroying pockets of enemy forces bypassed by the main body.

At H + 1.75 hours, the mortars and artillery shift to fire behind the first-echelon regiments and onto Objective Jack, respectively. Both mortars and artillery will fire a mix of HE and WP for obscuration and lethality.

The mortars shift fire onto Objective Jack at H + 2 hours, and the exploitation force positions for the final assault on the objective.

At H + 2.10 hours, the mortars and artillery shift fire beyond Objective Jack. The main attack force assaults the objective, destroying the enemy DAG.

#### *Pursuit Phase*

By H + 2.25 hours, it is obvious that the enemy can no longer maintain their position, and 2d Brigade is capturing significant numbers of soldiers and equipment. The enemy

resistance has crumbled. The enemy is now in full flight.

Upon securing the brigade follow-on objective, the brigade rapidly consolidates, and the commander orders them to conduct the pursuit. The direct pressure force moves rapidly forward along all available roads, bypassing small enemy pockets of resistance. The encircling force plans to move rapidly to the division objective and cut off the enemy retreat.

At H + 2.50 hours, aviation assets locate and mark the larger enemy formations with WP rockets. The mortars and artillery assets with the direct pressure force then fire successive belts of scatterable mines behind these larger formations. They also fire HE and HC mix onto the formations to further slow them and complicate command and control.

At H + 2.75 hours, the encircling force leaves its assembly area, moving rapidly along the western flank towards the division objective. By H + 3.5 hours, the encircling force has bypassed and outdistanced

the entire enemy formation. The encircling force commander now establishes a hasty defense, blocking the enemy's escape route.

At H + 3.75 hours, the smoke platoon starts its third mission. The smoke platoon begins to make a smoke curtain across the enemy's escape route, while the artillery and mortars from the direct pressure force stop firing smoke. This allows the direct pressure force to engage the enemy with direct fire weapons that are unobscured while concealing the encircling force's preparations.

At H + 4.25 hours, the enemy is forced into an engagement area between the direct pressure and encircling forces. The smoke from the smoke generator platoon silhouettes the enemy force for attack by the direct pressure force. At the same time, the encircling force is able to engage enemy forces through the smoke or as they emerge from the smoke on the other side. The enemy is destroyed and forced to surrender.

## Chapter 4

# Defensive Operations

Defensive operations retain ground, gain time, deny the enemy access to an area, and damage or defeat attacking forces. Smoke and obscurant use multiplies the

commander's ability to disrupt enemy attacks, seize the initiative, and project combat power at the critical time and place to defeat the enemy. Smoke and obscurant use

will support any type of defensive operation. Used correctly it will overcome any initial advantage of the attacker.

## Historical Perspective

During World War II, large-area smoke denied the Germans observation for directing accurate, indirect fire onto the US Fifth Army at Anzio. The 24th Decontamination Company landed at Anzio on D day, equipped with M1 smoke generators, M4 smoke pots, and eight Navy Besler generators.

On its first night ashore the unit smoked the beaches and anchorage. Within two days they had set up a smoke line nearly 2 miles long. As the beachhead forces expanded, other smoke troops, including a British unit and the US 179th Smoke Generator Company, moved to Anzio to increase the size of the cloud. Initially, smoke at Anzio was intended to be part of the anti-aircraft screen. This included making smoke at night, when flares dropped by lead planes appeared to be extinguished as they dropped into the smoke.

The Fifth Army's VI Corps began an end run that bogged down. The Germans contained the beachhead from its establishment on 22 January 1944 until the Allied breakout the following May. Experience showed that a favorite enemy tactic was low-level bombing attacks at dawn and dusk. Consequently, it soon became standard practice to smoke the port at dawn

and dusk and during red alerts for anti-aircraft defense. The Luftwaffe made at least one raid each night until mid-February, when the artillery fire increased. The Allies used 8-inch howitzers to demolish farmhouses suspected of harboring German observers. They fired smoke from chemical mortars and small-caliber artillery onto nearby ridges and towers.

Yet, enemy observers had an unrestricted view of the entire harbor from the mountains in the background for pinpoint firing with long-range guns. Although the entire beachhead was within range of enemy guns, the Allies failed to obscure the beachhead itself in January and February. The air defense, artillery, and naval commanders were afraid that smoke on the beachhead itself would interfere with observation for friendly fire and with unloading the ships at anchorage. From 22 January to 10 February alone, the Allies took average daily losses of almost 28 tons of ammunition from enemy long-range fire and bombing.

To reduce these losses, the corps chemical staff and chemical unit commanders, with the approval of the VI Corps commander, MG Lucian K. Truscott, developed a new technique for use of the

mechanical smoke generators. The technique resulted in the production of a light haze between the harbor and the front lines. The haze was thin enough to permit normal operations within it and thick enough to prevent German observation from the encircling hills.

On 18 March 1944, the 179th Smoke Generator Company moved from the harbor to forward positions. The smoke line formed a 15-mile arc around the port (Figure 8, on the next page), with 22 possible positions on land. Based on wind direction, 19 of those 22 positions had smoke generators. Also, two generators were mounted on Navy patrol craft in the harbor. The smoke generator positions were at 1,000-meter intervals just beyond the anti-aircraft positions of the port and just short of the field artillery observation posts. The latter prevented enemy observation from the flanks of the concave harbor. The smoke sections began operations ½ hour before dawn and made smoke until 14 hour after sunset every day from 18 March until after the breakout in May 1944. During this period, the Allied troops at Anzio were able to unload an average of 3,500 tons of supplies daily.

# Tactics

The National Training Center (NTC) is an area where smoke employment is possible on a large force-on-force scale. Key insights from the NTC for the defense include the following

- Smoke compresses the battlefield with engagements fought at shorter range.
- We must use alternate weapon positions in smoke.
- Smoke employment requires more detailed planning.
- Smoke can be used in deception, at night, and for obstacle reduction.
- Units that do not train in smoke do not perform well.

## Uses

Smoke and obscurants integrated throughout the defensive framework provide major disruptions to enemy synchronization providing windows of opportunity for our forces to seize the initiative and set the terms of combat. In the defense—

- Use smoke to support maneuver by—
    - Concealing disengaging and moving forces.
    - Slowing and disrupting enemy movement.
    - Isolating attacking echelons.
    - Concealing engineer operations and defensive preparations.
- In addition, use the guidance in

Chapter 3 for additional ways to support maneuver.

- Use smoke to provide additional firepower by disrupting enemy command and control and forcing the enemy to mass, thus providing a lucrative target. Other ways are identical to those in offensive operations. See Chapter 3.

- Use smoke to protect the force in the same way as in offensive operations. See Chapter 3.

In addition to the general techniques listed in Chapters 1 and 3, techniques to minimize interference in the defense include the following

- **Verify enemy locations** (responsibility of reconnaissance).
  - The enemy can use both our smoke and theirs to conceal move-

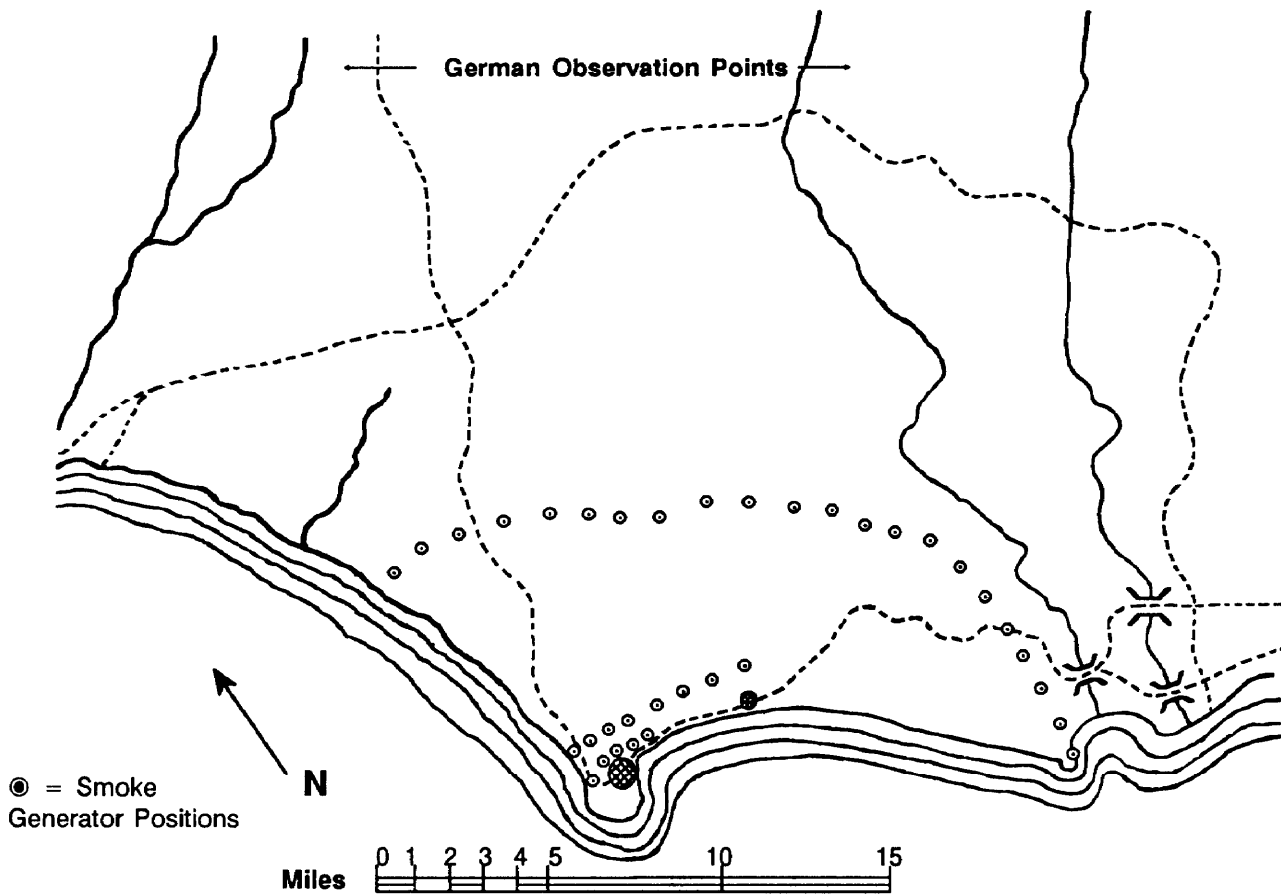

Figure 8. Smoke unit positions at Anzio Beachhead after 18 March 1944.

ment to alternate positions or to break contact.

– Aggressive reconnaissance before and during the engagement will allow you to shoot and remain in contact.

– You can use aviation assets to spot and mark enemy targets for destruction by indirect and direct fire.

● **Plan and use all sensor and viewer capabilities.** Consider placing ground surveillance radar, air defense weapons, and target acquisition radars on the flanks or high ground to acquire targets through the smoke. Maintain communications between these systems and both direct and indirect fire elements. Use the acquisition element

to observe and adjust direct and indirect fire at targets.

● **Plan for enemy countermeasures.** Enemy forces will counter your smoke. The enemy may use countersmoke to confuse our command and control, so avoid reliance on visual signals. The enemy will increase use of indirect fire weapons when direct fire target acquisition is ineffective. Therefore, plan artillery counterbattery and countersmoke fire when you stop or delay the enemy.

### Goal

As in offensive operations, the main focus of smoke in the defense is to defeat enemy target acquisition and reconnaissance, and to conceal

maneuver and support forces. Our intent is to deny the enemy information about the disposition and composition of our forces. That allows us to gain time, concentrate forces elsewhere, control key or decisive terrain, and wear down enemy forces as a prelude to offensive operations.

Our overall goal is to improve the commander's ability to retain his initiative in operations against a potentially numerically superior force. Appendix A contains tactical decision aids for determining which smoke delivery means to use against the specific smoke targets covered by the tactics for using smoke in defensive operations.

The five complementary elements of the defense are deep operations forward of the FLOT, security force operations forward and to the flanks of the defending force, defensive operations in the main battle area (MBA), reserve operations in support of the main defensive effort, and rear operations.

### Deep Operations

In the defense, deep operations are aimed at preventing the enemy from concentrating overwhelming combat power by disrupting their momentum and destroying the coherence of their attack. In deep operations, use smoke to —

- Force the enemy to deploy into our strength.
- Defeat or disrupt command and control efforts.
- Isolate reinforcing echelons from the assault force.

Smoke employment tactics in deep operations are identical to those in offensive operations (preparation phase). See Chapter 3.

## Elements of Defense

### Security Force Operations

The fundamental purposes of security force operations are to defeat and destroy enemy reconnaissance forces, force the enemy to deploy, confirm the direction and strength of the enemy attack toward the main body, and buy time for the main body to deploy forward and laterally. Use smoke in security force operations to—

- Conceal movement of maneuver and support forces, allowing the commander to mass forces unobserved.
- Provide tactical surprise, allowing the commander to seize the initiative and set the terms of combat.
- Defeat enemy reconnaissance and counterreconnaissance efforts.
- Conceal obstacle emplacement.

The first part of the defensive battle that the friendly commander must win is counterreconnaissance. Counterreconnaissance is an integral part of the security mission. The focus of the Threat's reconnaissance is to confirm or deny the dispositions and intentions of our

force. Use smoke as an active counterreconnaissance measure to—

- Fix the enemy reconnaissance force.
- Mark the enemy reconnaissance force for destruction with direct and indirect fire weapons.
- Deny the enemy reconnaissance force information about the disposition, composition, or intent of friendly forces.

Smoke employment tactics in counterreconnaissance are the following:

- Screening smoke. Use screening smoke to conceal maneuver and obstacle emplacement. Use smoke in the security force area and along the flanks to conceal movement. Use smoke forward of the battle hand over line to allow the security force to disengage. You must carefully control the smoke to prevent silhouetting your units.
- Protecting smoke. Use protecting smoke to defeat enemy antitank and air defense systems.
- Obscuring smoke. Use projected smoke mixed with high-explosive rounds before the enemy can pinpoint your units. Plan obscuring fire based on decision points for the enemy to isolate and confuse their

reconnaissance forces. Plan obscuring fire during the battle hand over to allow the security force to disengage and pass through friendly lines unobserved.

- Marking smoke. Use marking smoke to mark enemy targets for rapid destruction or to reduce the potential for firing on friendly forces. Aviation reconnaissance assets are particularly useful to spot the reconnaissance force and mark it with helicopter-delivered smoke rockets.

- Smoke for deception. Uses are identical to those in offensive operations (preparation phase). See Chapter 3. Figure 9, below, shows smoke employment in security operations.

## Main Battle Area

The decisive battle usually takes place in the MBA. The defender concentrates the strongest possible forces for decisive action against the enemy main effort. Use smoke to –

- Defeat enemy target acquisition efforts without degrading our own ability to acquire and engage.
- Create opportunities for commanders to seize the initiative locally and attack.
- Slow the advance of the attacking force.
- Separate and isolate the attacking echelons.
- Force enemy infantry to dismount.
- Disrupt the enemy's ability to exercise command and control.

- Once the enemy is in the engagement area of our choosing, prevent them from breaking contact so we can destroy them immediately.

Smoke employment tactics in the MBA are the following:

- Obscuring smoke. Use obscuring smoke to isolate the engagement area and counterattack or spoiling attack objectives, defeat enemy target acquisition and guidance systems, and defeat reconnaissance and counterreconnaissance efforts. Use projected smoke means to deliver smoke mixed with high-explosive rounds in front of the objective; between enemy formations; and on identified forward observer, ATGM, and tank unit positions before the enemy can pinpoint your units as targets. Using projected

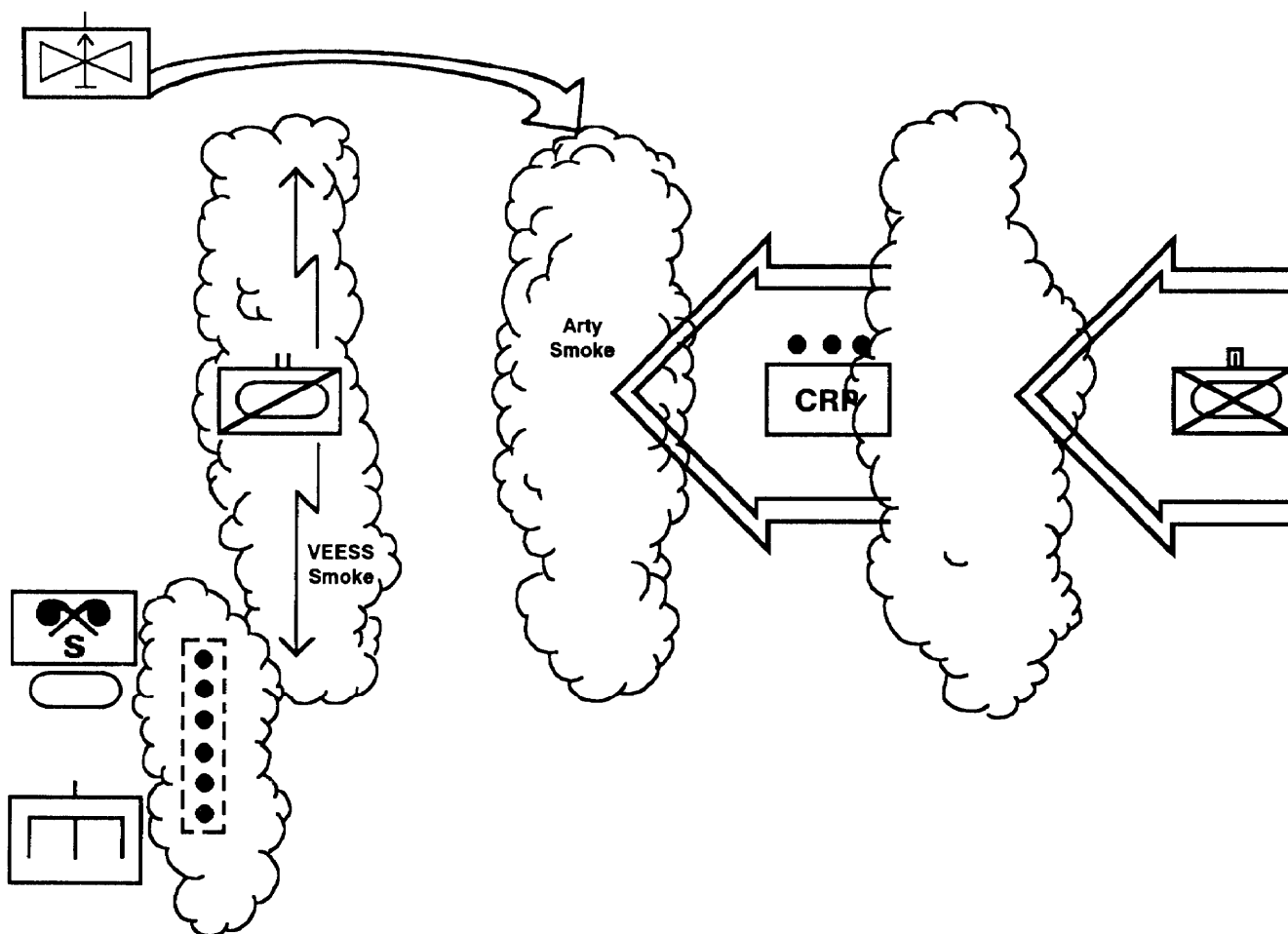

Figure 9. Example of smoke use in security force operations, with helicopter and artillery smoke marking and obscuring enemy formations; thus, isolating them from each other and denying their RSTA efforts. The cavalry squadron uses its VEESSs to conceal the location of the main battle positions from direct observation. Mechanized smoke assets conceal engineer obstacle emplacement, protecting that critical asset from interdiction.



smoke as countersmoke and to isolate the objective can significantly interfere with the enemy commander's synchronization.

- Screening smoke. Use screening smoke to conceal maneuver as you move to new positions; conceal the force as you bypass, breach, or cross obstacles or small pockets of resistance in counterattack or spoiling attack; along the flanks to protect the force; and in the rear to conceal disposition and composition of reserves. Use self-defense and generated-smoke means to deliver smoke across danger areas and to the flanks of the force to limit enemy observation and engagement.

- Identifying smoke. Use the same technique as in the security force operations.

- Protecting smoke. If the enemy has known or suspected directed-energy weapon capability, concealing your force in a blanket of oil smoke will attenuate some of the energy.

- Smoke for deception. Use this smoke to draw attention away from the main defensive effort and the counterattack or spoiling attack to areas of little or no importance. Use generated-smoke to create small- to large-area smoke away from the main body.

## Reserve Operations

The primary purpose of the reserves in the defense is to counterattack, to exploit enemy weaknesses, and to reinforce forward defensive operations. Use smoke in reserve operations to—

- Deny the enemy information about the location and strength of reserve forces.

- Conceal movement of reserve forces, allowing the commander to mass forces unobserved.

- Provide tactical surprise, allowing the commander to seize the initiative and set the terms of combat.

The employment tactics for smoke support in reserve operations depend on how, when, and where the commander chooses to use his reserves. In general, the tactics for

smoke employment for reserves in a counterattack or spoiling attack role are the same as smoke tactics for the preparation phase of offensive operations. For reserve forces in a reinforcing role, the smoke tactics are the same as those for security force operations in the defense.

## Rear Operations

We conduct rear operations to allow the commander freedom of maneuver and for continuity of operations, to include continuity of sustainment functions and command and control. Use smoke in rear operations to—

- Conceal support forces, facilities, and activities. Reducing enemy observation reduces the necessity to move frequently. When necessary, conceal movement of support forces.

- Deny the enemy use of landing zones and/or drop zones.

- Isolate enemy forces in the rear area.

- Defeat rear area Threat acquisition efforts and support base, base cluster, and rear operations response to the Threat.

Smoke tactics in rear operations are also dependent upon the commander's intent and the threat. In general, use smoke to attack enemy target acquisition and engagement efforts when identified. The smoke employment tactics are similar to those for a hasty attack. Figure 10, on the next page, illustrates smoke use in rear area operations.

## Example

The following example depicts a mechanized infantry heavy brigade conducting the movement to contact. The brigade is the 2d Brigade, 54th Infantry Division (M). Smoke delivery means include the direct support artillery battalion, battalion mortars, smoke generator platoon, VEES, smoke pots, smoke grenades, and aviation assets on-call. 2d Brigade will defend in sector, commencing at H-hour. The commander's intent is to force the

enemy to deploy prematurely, seize the initiative, and conduct local counterattacks to destroy the enemy force.

*Intelligence indicates the enemy is the 1st Guard Motorized Rifle Division, 2d Combined Arms Army, which relieved another motorized rifle division and is conducting a meeting engagement from the march. The enemy is marching by regiments, with three regiments in front and a combined arms reserve instead of a second echelon. Terrain is fairly open to the west of Hill 268 but is restricted to the east of Hill 352. The enemy has excellent observation and fields of fire from both hills.*

*At H - 48 hours, the commander issues the restated mission and his planning guidance. The brigade chemical officer, S2, and FSO go to the intelligence cell and begin target development.*

*The brigade chemical officer has completed his estimate at H - 42 hours and provides a draft target list to the FSO. While the brigade chemical officer briefs the commander, the brigade chemical NCO continues smoke target analysis in coordination with the smoke platoon leader.*

*At H - 36 hours, the brigade chemical officer, FSO, and smoke platoon leader finalize the smoke support plan. This includes a draft smoke support annex to the brigade OPORD.*

*At H - 33 hours, the brigade commander approves the final OPORD. The brigade commander and staff issue the order to the commanders and specialty unit leaders.*

*Three hours later, the smoke platoon makes smoke to conceal obstacle emplacement.*

*At H - 24 hours, the brigade chemical officer finalizes smoke support coordination with all units. This includes coordination with adjacent units that might be affected by smoke if the wind shifts.*

*At H - 20 hours, the brigade chemical NCO verifies with the FScell that the additional smoke munitions for the artillery and mortars are on hand and prepositioned.*

The brigade chemical officer receives a brief back from the smoke platoon leader and assistant S3 (operations) officer at H -18 hours. These officers verify rehearsals in the smoke platoon and maneuver units (for on-board smoke use). The FScell and chemical cell also check communications circuits at this time.

At H - 15 hours, aviation reconnaissance spots enemy divisional reconnaissance assets. Helicopter-delivered rockets mark this enemy element for destruction by CAS aircraft.

At H - 12 hours, the security force encounters enemy reconnaissance assets. Based on the commander's decision support template, the DS artillery battalion begins to fire a mixture of HE and smoke (HC) onto identified targets. Mortars moving with the security force also fire a mixture of HE and smoke (WP) between the security force and the reconnaissance assets. This will deny the

enemy information and confuse them as to the location and disposition of our force.

Thirty minutes later, the security force engages the enemy reconnaissance with direct fire weapons. Artillery and mortar fire shift to behind the enemy reconnaissance force. This shifting of fire silhouettes the enemy, isolates the enemy, and prevents obscuration of our own direct fire

At H - 8 hours, the security force identifies elements of the enemy FSE moving into the brigade area of operations. Aviation and artillery assets mark targets with WP for attack by CAS aircraft.

The security force, at H - 6 hours, identifies elements of the enemy AG moving into the brigade area of operations. The smoke platoon stops smoke at the obstacle emplacement.

At H - 2 hours, the security force begins to withdraw. Security force mortars fire HE and WP mix to

allow the security force to disengage. The smoke platoon makes smoke at the battle hand over line to conceal the rearward passage of lines.

At H-hour, aviation reconnaissance identifies elements of the division main body entering the brigade area of operations. The security force has done its job and forced the enemy to deploy along the western approach, avoiding the high ground on Hill 352. The artillery begins to fire on the flanks and forward elements of the enemy AG and main body. The mortars begin to fire on the flanks and forward elements of the enemy FSE. Both use a mixture of HE and WP. This will isolate the enemy forces and serve as good reference points for adjusting indirect and direct fire.

At H + 30 minutes, the enemy main body has entered the engagement area. Our indirect fire has caused attrition to their FSE and A G

and forced the main body into our strength. The brigade commander now orders the artillery to fire FASCAM mixed with HC behind the engagement area to delay reinforcements and to isolate the main body for destruction.

At H + 1 hour, the direct fire fight has begun. Artillery fire switch to HE and HC mix. Mortars fire HE onto the enemy and WP onto the flanks. Our GSR teams pass target acquisition information to the TOW sections of each company. Our forces use thermal sights to acquire and engage the enemy, who cannot see through the smoke.

By H + 2 hours, the enemy commander is unable to maintain his momentum and begins to withdraw.

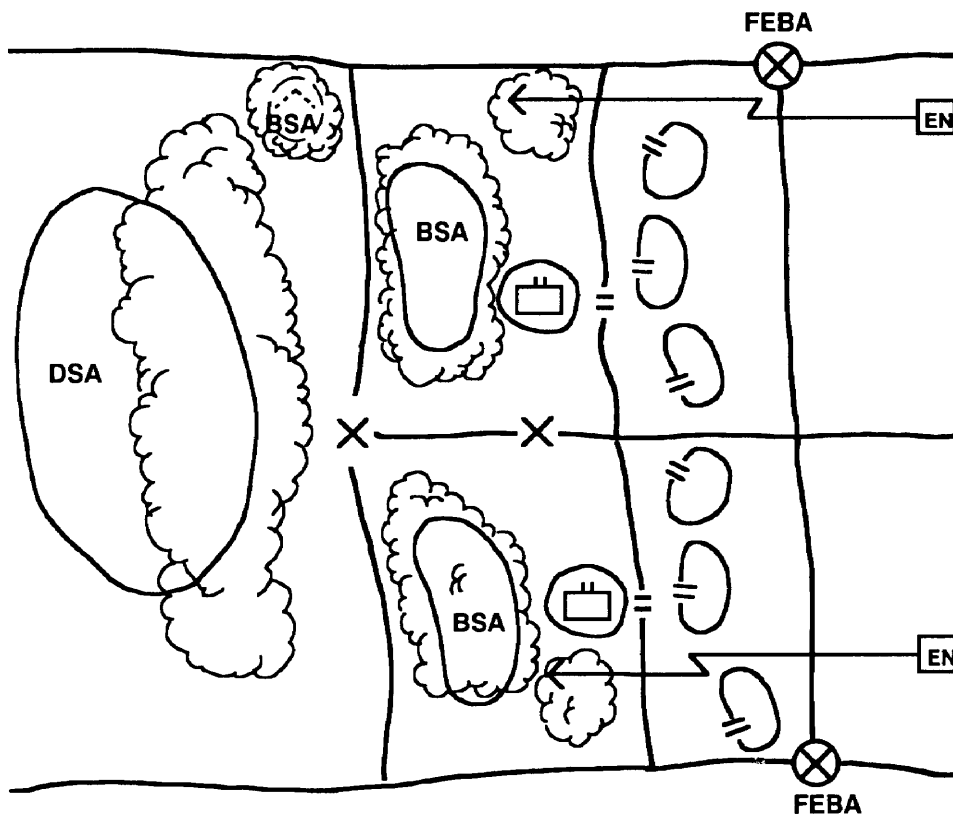

Figure 10. This example of smoke employment in rear operations uses large-area smoke clouds to conceal support activities from enemy RSTA efforts. A dummy BSA also has smoke support to complicate enemy intelligence gathering and to make our deception plan more believable. If enemy forces penetrate to our rear area, a mixture of HE and WP will delay their movement and mark them for destruction by responding forces.

## Chapter 5

# Other Tactical Operations

Other tactical operations cover a wide range of special-purpose operations undertaken routinely during offensive and defensive operations. While these operations are not the main focus of the commander at the tactical level of war, smoke may support these operations as well. These operations include—

- Retrograde operations.

- Relief-in-place operations.
  - Passage of lines.
  - Linkup operations.
  - Breakout from encirclement.
  - River crossings.
  - Obstacle breaching.
- In addition, there are special conditions and environments we must consider:
- Mountains.

- Jungles.
  - Urban terrain.
  - Deserts.
  - Winter zones.
  - Nuclear, biological, and chemical (NBC) conditions.
- Finally, because smoke draws attention, we must consider smoke support for tactical deception.

## Tactics

Smoke and obscurants integrated throughout the battlefield and operational continuum provide major contributions to combat power in deep, close, and rear operations. In other operations, the major contributions are the same as those in offensive smoke tactics. See Chapter 3.

Smoke and obscurant use in other tactical operations requires the same careful planning and execution as with the offense and defense. In addition to the general

techniques listed in Chapter 3, special techniques to minimize interference include—

- **Know the limitations of your delivery systems.** Smoke munitions do not behave the same in all conditions or environments (for example, the jungles of Central America versus the woodlands of Europe). Plan for differences in coverage. Some munitions combinations such as HE and WP are not effective under certain environments or conditions

such as winter zones with deep snow.

- **Use smoke to mask terrain from aerial observation.** With the exception of jungles, much of the terrain described in this chapter affords good aerial observation. By masking key terrain features you reduce your vulnerability as targets of opportunity for high-performance aircraft.

## Retrograde

A retrograde operation is a movement to the rear or away from the enemy.

Retrograde operations gain time, preserve forces, avoid combat under undesirable conditions, or draw the enemy into an unfavorable position. In retrograde operations—

- Use smoke to support maneuver by—
  - Concealing maneuvering forces from enemy observation.
  - Concealing disengaging and moving forces.

- Providing tactical surprise and allowing the commander to set the terms of combat.
- Allowing the commander to mass forces unobserved.
- Defeating enemy surveillance efforts.
- Supporting the deception story.
- Slowing and disrupting enemy movement.
- Isolating attacking echelons.
- Concealing engineer operations defensive preparations to the rear

- Use smoke to provide additional firepower by—
  - Defeating enemy counterreconnaissance efforts.
  - Disrupting enemy command and control.
  - Disrupting enemy maneuver and reinforcement.
  - Disrupting the enemy's ability to communicate.
  - Forcing the enemy to mass, thus providing a lucrative target.
  - Changing friendly to enemy force ratios by using thermal imagers and

millimeter wave acquisition devices such as radars to see through visual smokes and using smoke to isolate defending and second-echelon forces.

– Enhancing friendly target acquisition efforts by silhouetting enemy vehicles with smoke and using smoke and obscurants we can see through but the enemy cannot.

- Use smoke to protect the force. (See Chapter 3 under Offensive Smoke Tactics.)

## Delay

In delays, units give ground to gain time. Delaying units inflict the greatest possible damage on the enemy while preserving their freedom of action.

In the delay, use smoke to–

- Conceal movement of maneuver and support forces, allowing the commander to mass forces unobserved.

- Provide tactical surprise, allowing the commander to seize the initiative and set the terms of combat.

- Defeat enemy reconnaissance and counterreconnaissance efforts.

- Conceal obstacle emplacement, breaching, or crossing.

- Conceal designated withdrawal routes.

- Maintain contact with the enemy but preclude decisive engagement.

Smoke employment tactics in the delay are the following:

- ▣ **Screening smoke.** Use screening smoke to conceal maneuver and obstacle emplacement. Use smoke along withdrawal routes and along the flanks to conceal movement. Begin making smoke prior to departing your existing position to confuse the enemy as to the actual location and size of

the force. Use projected means to deliver smoke between the delaying unit and the enemy force. Use smoke to conceal obstacle breaching or crossing. The priority of effort is to mobility operations; therefore, carefully control the smoke to prevent slowing or silhouetting your units.

- **Protecting smoke.** Use protecting smoke as required to defeat enemy ATGMs and air defense systems. Use protecting smoke to avoid decisive engagement.

- **Obscuring smoke.** Use obscuring smoke to defeat enemy reconnaissance and counterreconnaissance efforts. Use projected smoke means to deliver smoke mixed with high-explosive rounds before the enemy can pinpoint your units. Attempt to force the enemy into early deployment.

- **Marking smoke.** Use marking smoke to mark enemy targets for rapid destruction or to reduce the potential for firing on friendly forces.

- **Smoke for deception.** Use supporting smoke to draw attention to areas of little or no importance. Create large-area smoke away from the delaying force. Consider using smoke mixed with high-explosive rounds to conduct preparatory fire of dummy objectives.

## Withdrawal

In withdrawals, a force in contact disengages from the enemy. The force may be assisted by another force or unassisted. In the withdrawal, use smoke to–

- Conceal movement of maneuver and support forces, allowing the

## Relief in Place

- Mark the enemy reconnaissance force for destruction with direct and indirect fire weapons.

- Deny the enemy reconnaissance force information about the disposition,

commander to mass security forces unobserved.

- Defeat enemy reconnaissance and counterreconnaissance efforts.

- Conceal obstacle emplacement, breaching, or crossing and hinder pursuit by the enemy.

- Conceal designated withdrawal routes, traffic control points, and on-order assembly areas.

- Create opportunities to disengage the force.

Smoke employment tactics in the withdrawal include the following:

- **Screening smoke.** The tactics are the same as those under Delay. Additionally, use projected means to deliver smoke between the security force and the enemy force.

- **Protecting smoke.** The tactics are the same as those under Delay.

- **Obscuring smoke.** The tactics are the same as those under Delay.

- **Marking smoke.** The tactics are the same as those under Delay.

- **Supporting smoke for tactical deception.** Use supporting smoke to draw attention to areas of little or no importance. Create large-area smoke away from the main body.

## Retirement

In a retirement, a force not in contact moves away from the enemy in an organized manner. In a retirement, a heavy rear guard will conduct delaying actions to slow the advance of the enemy and allow the main body to increase the distance between itself and the enemy. In general, use smoke to support the rear guard in its delaying operations. The tactics for employment of smoke in support of the rear guard are the same as for the delay.

In a relief in place, a unit in contact is replaced by another that assumes the missions of the outgoing unit. Use smoke to–

- Fix the enemy reconnaissance force.

tion, composition, or intent of friendly forces.

- Conceal the movement of relieving forces. This is critical as dispersion of forces in a relief is difficult. The enemy may exploit the massing

as a time to attack with NBC weapons.

A special consideration for reliefs is to maintain the illusion the force has not changed. Obtain the relieved force's smoke annex. In planning the relief, attempt to duplicate patterns of employment for a brief period.

Smoke employment tactics in a relief in place are the following:

- Screening smoke. Use screening smoke to conceal maneuver. Use smoke in the reserve force area and along the flanks to conceal move-

A passage of lines is a coordinated movement of one or more units through another unit. Units conduct passage of lines to continue an attack or counterattack, envelop an enemy force, pursue a fleeing enemy, or withdraw a security or main battle force. Synchronization is the overriding imperative. Use smoke to—

- Conceal movement of maneuver and support forces, allowing the commander to mass forces unobserved.
- Provide tactical surprise, allowing the commander to seize the initiative and set the terms of combat.
- Defeat enemy reconnaissance and counterreconnaissance efforts.

Two friendly forces are joined in linkup operations. Units conduct linkup operations to complete an encirclement of an enemy force, assist in breakout of an encircled friendly force, or to join an attacking force with a force inserted into the enemy rear.

Use smoke to—

- Mark the coordinated fire line (CFL) or the restrictive fire line (RFL) to prevent fires being set by friendly forces.
- Conceal movement of the linkup force.

ment. Use smoke forward of the FLOT to allow the relieved force to disengage. You must carefully control the smoke to prevent silhouetting your units.

- Protecting smoke. Use protecting smokes to defeat enemy antitank and air defense systems.
- Obscuring smoke. Use projected smoke means to deliver smoke mixed with high-explosive rounds before the enemy can pinpoint your units. Plan obscuring fire based on decision points for the enemy, isolating and confusing their reconnais-

## Passage of Lines

- Conceal obstacle breaching or bypass.

Smoke employment tactics in passage of lines are the following:

- Screening smoke. Use screening smoke to conceal maneuver and obstacle breaching. Use smoke at the contact point, along passage lanes, and along the flanks to conceal movement. Use smoke forward of passage points. You must carefully control the smoke to prevent silhouetting your units.
- Protecting smoke. Use smoke to defeat enemy antitank and air defense systems.
- Obscuring smoke. Use projected smoke means to deliver smoke mixed with high-explosive rounds before the enemy can pinpoint your

## Linkup Operations

- Deny the enemy information concerning when and where the linkup will occur.

Smoke tactics for linkup operations are the following:

- Obscuring smoke. The tactics are the same as those for the exploitation phase of offensive operations (Chapter 3).
- Screening smoke. Use screening smoke to conceal maneuver and support forces and defeat enemy target acquisition and guidance systems. Use self-defense and generated-smoke means to conceal maneuver

sance forces. Plan obscuring fire during the relief to allow the relieved force to disengage and pass through friendly lines unobserved.

- Marking smoke. Use marking smoke to mark enemy targets for rapid destruction or to reduce the potential for firing on friendly forces. Use aviation reconnaissance assets to spot the enemy reconnaissance force and mark it with smoke rockets.
- Supporting smoke for tactical deception. The tactics are the same as in the withdrawal phase.

units. Plan obscuring fire based on decision points for the enemy, isolating and confusing their reconnaissance forces. Plan obscuring fire during the passage of lines to allow the force to pass through friendly lines unobserved.

- Marking smoke. The tactics are the same as those under Relief in Place.
- Supporting smoke for tactical deception. Use supporting smoke to draw attention to areas of little or no importance. Create large-area smoke away from the main body. Consider using smoke mixed with high-explosive rounds to conduct preparatory fire of dummy objectives.

units as they bypass or harass enemy forces.

- Marking smoke. Use marking smoke to mark the CFL or RFL, mark targets for destruction, identify bypass routes, and signal for battlefield activities. Use projected smoke means to deliver smoke onto identified enemy strongpoints or larger formations and to signal forces to consolidate on a particular objective or rally point.
- Protecting smoke. If the enemy has known or suspected nuclear or directed-energy weapon capability,

concealing your logistics activities in oil smokes may attenuate some of the energy.

- Smoke for deception. Use this smoke to keep the enemy off-

balance and to draw attention away from critical sustainment activities.

## Breakout from Encirclement

A breakout from encircled forces differs from other attacks only in that units must maintain a simultaneous defense of other areas of the perimeter.

Use smoke to—

- Aid in establishing a deception story.
- Isolate and segregate enemy forces to create gaps or weaknesses in the encircling force.
- Conceal movement of maneuver and support, allowing the commander to mass the rupture force and main body unobserved.
- Defeat enemy reconnaissance and counterreconnaissance efforts.
- Conceal obstacle emplacement, breaching, or crossing and hinder pursuit by the enemy.
- Create opportunities to disengage the force.

Smoke employment tactics in breakout from encirclement include—

- Obscuring smoke. Use obscuring smoke to isolate the rupture objective, defeat enemy target acquisition and guidance systems, and defeat reconnaissance and counterreconnaissance efforts. Use projected smoke means to deliver smoke mixed with high-explosive rounds in front of the objective; between enemy formations; and on identified forward observer, ATGM, and tank unit positions before the enemy can pinpoint your units as targets.
- Screening smoke. Use screening smoke to conceal maneuver as you bypass, breach, or cross obstacles or small pockets of resistance, along the flanks to protect the force, and in the rear to conceal disposition and composition of both the reserves and rear guard. Use self-defense and generated-smoke means to deliver smoke across danger areas and to the flanks of

the force to limit enemy observation and engagement.

- Marking smoke. Use marking smoke to mark enemy targets for rapid destruction or to reduce the potential for firing on friendly forces.
- Protecting smoke. If the enemy has known or suspected directed-energy weapon capability, concealing your force in a blanket of oil smoke will attenuate some of the energy.
- Smoke for deception. Use this smoke to draw attention away from the main effort to areas of little or no importance. Since the diversionary force is critical to the breakout, consider making it the priority for smoke support. Use generated-smoke means to create small- to large-area smokes away from the main body.

## River Crossings

Units conduct river crossings as part of a higher headquarters scheme of maneuver. The commander's objective is to project his combat power to the exit side of the river quickly to maintain the unit's momentum. The overriding imperative is synchronization. Effective command and control are critical for success. Apply all techniques to minimize the interference caused by smoke. Use smoke to—

- Conceal the movement of the initial assault force.
- Isolate the exit bank of the river for rapid occupation by maneuver forces.
- Conceal emplacement of crossing means such as engineer bridges.
- Isolate follow-on objectives to allow the commander to rapidly

project combat power across the river.

Smoke employment tactics in river crossings include—

- Screening smoke. Use screening smoke to conceal maneuver and actual river crossing sites. Use smoke in the main body area and along the flanks to conceal movement. You must carefully control the smoke to prevent silhouetting your units. Begin making smoke prior to conducting the initial assault to confuse the enemy as to the actual location and size of the force. Use projected-smoke means to deliver the initial screening smoke to isolate the exit bank objectives and give other smoke delivery means time to build effective smoke.

- Protecting smoke. Use protecting smoke as required to defeat enemy ATGMs and air defense systems.

- Obscuring smoke. The tactics are the same as in the preparation phase for offensive operations (Chapter 3).
- Marking smoke. Use marking smoke to mark enemy targets for rapid destruction or to reduce the potential for firing on friendly forces. Aviation assets can deliver smoke onto identified enemy positions for destruction by indirect fire or the follow-on force.
- Smoke for deception. The tactics are the same as in the preparation phase for offensive operations (Chapter 3).

## Obstacle Breaching

Units breach obstacles when they cannot bypass them at an advantage. The commander's objective is to project his combat power to the exit side of the obstacle quickly to maintain the unit's momentum. The overriding imperative is initiative. In general, platoons and larger formations breach obstacles, with most smoke planning consisting of immediate fire requests for covert or hasty breaches or detailed planning for all potential smoke assets in deliberate breaches.

Use smoke to—

- Isolate the exit side objective.

- Conceal movement of the breaching, initial assault, and support forces.

- Conceal emplacement of crossing means such as engineer bridges or demolitions.

- Isolate the exit side of the obstacle for rapid occupation by maneuver forces.

- Isolate follow-on objectives to allow the commander to rapidly project combat power across the obstacle.

Smoke employment tactics for breaching include—

- Screening smoke. The tactics are the same as those under River Crossings.

- Protecting smoke. Use protecting smokes as required to defeat enemy ATGMs and air defense systems.

- Obscuring smoke. The tactics are the same as in the preparation phase for offensive operations (Chapter 3).

- Marking smoke. The tactics are the same as those under River Crossings.

- Smoke for deception. The tactics are the same as in the preparation phase for offensive operations (Chapter 3).

## Special Conditions or Environments

Weather and terrain have a significant impact on smoke employment as previously stated. The following paragraphs present special climate considerations, employment tactics, and techniques to overcome difficulties under these conditions:

- Mountains.
- Jungles.
- Urban terrain.
- Deserts.
- Winter zones.
- Nuclear, biological, or chemical (NBC) conditions.

### Mountains

In combat operations, mountains generally are characterized by rugged, compartmented terrain; steep slopes; and few natural or man-made lines of communication. The weather spans the entire spectrum from extreme cold, with ice and snow during winter, to extreme heat in some areas during summer. Although these extremes are important planning considerations, the variability of weather over short periods of time, and from area to area, also significantly influences maneuver, fire support, and smoke support operations.

### Delivery Means

Mountainous terrain is generally hard and rocky in the summer with intermittent areas of deep snow. In the winter, the terrain is mostly covered with deep snow.

- Snow. The phosphorus in WP can burn undetected in snow for up to four days.

- Rocky terrain. Smoke is effective to deny the enemy the use of narrow passages, valleys, roads, and usable terrain.

- Winds. Swirling winds make smoke employment very difficult to adjust and maintain. Close coordination is required with adjacent elements to ensure that their vision is not obscured or they are not highlighted.

- Adjusting fire. Distances are difficult to judge. Observers tend to underestimate upslope distances and overestimate downslope distances.

### Problems

Mortars are ideal because of their high-angle fire. They can deliver fire on reverse slopes and over intermediate crests.

Position observers on high ground and spread them to overcome terrain masks and compartments. Ob-

servers may require mountaineering equipment to get to the best positions, or they may be airlifted. Terrain sketches and visibility diagrams are essential to deliver fast, accurate fire and to identify blind spots.

Use ground surveillance radars and remote sensors to acquire targets. Use smoke to—

- Deny enemy use of narrow passages, valleys, roads, and usable terrain.

- Isolate enemy formations for piecemeal destruction.

- Obscure routes that can be used by the enemy to attack, withdraw, and resupply.

- Obscure likely position areas for indirect fire assets, command and control elements, CSS assets, and observation posts.

- Conceal terrain that is subject to snowslides, flash floods, and rockslides.

### Jungles

Usually, jungle operations are carried out by light forces that can get into and out of areas by helicopter. Fire support may be limited to indirect fire and air support. Because small-unit operations are com-

monplace, greater challenges accrue to the chemical officers and fire support coordinators (FSCOORDs) at lower levels such as the company FSO and the battalion chemical officer.

### **Delivery Means**

In jungle terrain, most contact with the enemy will be at extremely close ranges. If the friendly force has a substantial advantage in fire support, the enemy will most likely try to come in as close as possible and maintain that close contact so that the friendly force cannot employ their fire support advantage without inflicting casualties on their own troops.

In the triple-canopy jungle, HC smoke is ineffective. WP is effective as a marking round and in initial adjustments. ICM and FASCAM will hang up in the trees and endanger friendly forces that later move through the area. Illumination rounds are ineffective because the chutes get caught in the upper canopy.

The triple-canopy jungle makes observation beyond 25 to 50 meters very difficult. The jungle also makes map reading and self-location, target location, and friendly unit location determinations very difficult.

### **Problems**

Experience from World War II and Vietnam showed that observers and smoke control officers must be able to adjust smoke and mortar and field artillery (FA) fire by sound because they often cannot see the rounds to adjust them. This sound adjustment is very difficult and requires wide experience.

By taking the recommended adjustments of two or more observers in different locations, some accuracy can result. The battery fire direction center (FDC) can help by announcing SPLASH to let the observer know when the round should impact. The observer then counts the seconds until he hears the round detonate. Multiplying the seconds by the speed of sound, the

observer can estimate the range to impact. The speed of sound is approximately 350 meters per second. The speed of sound varies according to temperature, wind speed and direction, relative humidity, and air density; but 350 meters per second should be used as a start point.

The observer and smoke control officer must determine their locations and ensure that the TAC CP and FDC have them plotted. If the observer or smoke control officer's initial position locations are way off, the smoke will be way off too. Use the initial smoke to determine the observer's own location.

Vietnam and World War II also showed that the first projected round in adjustment must be WP smoke. Because the observers are not sure of their own location or that of other friendly elements, WP was always fired first to avoid inflicting casualties on friendly personnel.

Creeping fire was also used extensively in Vietnam and World War II. The observer adds 300 to 400 meters to his target location in case his own position location is wrong. Then he makes corrections of no more than 50 meters until the fire is on target. In Vietnam, this process sometimes started with an aerial observer and was taken over by the ground observer once he was able to see the rounds. The aerial observer was often required to relay fire requests from the ground because the terrain severely limited the ranges of radio communications.

Because of the close combat, laser range finders may not be of great use; however, night vision devices are extremely critical. Avoid using projected smokes during limited visibility periods to preclude degradation of these devices. Aerial observers help direct CAS assets against enemy targets. Because ground observers cannot see the whole battlefield, the aerial observer marks targets for the CAS sortie (flares, WP, smoke). Radars are extremely effective in the jungle, since most indirect fire is high-angle

fire. Ground surveillance radars and remote sensors must be used.

Use smoke—

- To conceal maneuver to the front, flanks, and rear.
- Along roads and trails to deny enemy use.
- At likely ambush sites to obscure enemy observation and fields of fire.

### **Urban Terrain**

In urban terrain, ranges are drastically reduced. There are three major types of terrain in nearly every built-up area:

- Obstructions, such as buildings and heavily wooded parks.
- Flat, open terrain over water, such as rivers and lakes.
- Flat, open terrain over concrete or asphalt, such as parking lots, multiple-lane roads and highways, and open lots.

Air currents are unpredictable. Obstructions tend to break up smoke streamers, which re-form into a more uniform cloud. Convection currents over open areas cause smoke to rise. There are many observation points at multiple levels, which allows an enemy to observe from either above or below smoke.

### **Delivery Means**

Downwind coverage is often less due to obstructions breaking up the smoke, unpredictability of air currents, and smoke following street patterns. The Berlin Brigade observed that open areas in cities tend to cause smoke to rise and obscure key observation points. This is a particular problem over water, garden plots, and wide expanses of concrete.

Smoke diffuses well at night but tends to rise to rooftop level about one hour after sunrise until one hour after sunset. Burning rubble degrades the screening efficiency of smoke. Smoke pots weigh between 27.5 and 33 pounds (M4/M5), making it difficult for infantry squads to employ without transportation assets to move them forward first.



Smoke hand grenades make smoke for only 60 to 150 seconds. Squads need to carry four to six per person for concealment. Because of the height and closeness of buildings and other obstructions, CAS and artillery fire is degraded. Mortars and high-angle artillery are still effective.

### Problems

Smoke and obscurant use in military operations on urbanized terrain (MOUT) requires careful planning and execution to prevent interference with movement, assault operations, or target acquisition; to retain the element of surprise; and to avoid silhouetting or drawing undue attention to friendly forces.

Time smoke delivery with decision points. Conduct a thorough IPB and time your use of smoke to key decision points in your tactical plan: for example, "When we reach Sector A1, use grenade launchers to smoke the open area and conceal movement of B Company as they emplace smoke pots.") Ensure you target key terrain to deny the enemy the use of it.

Use unobscured weapons to overwatch. The overwatching elements should have target acquisition devices such as thermal imagers that can see through our own smoke and engage the enemy. This prevents surprise and enhances your ability to suppress enemy fire during the assault. This is particularly important for observers in upper floors of buildings, enabling them to observe enemy movements while friendly forces move unobserved.

Limited visibility positions, preplanned and previously prepared, will minimize degradation caused by friendly or Threat use of smoke. Rehearsal of displacement under smoke will help you avoid confusion and disorientation. It will also rapidly restore engagement capability.

The best tactical application of smoke in urban areas is smoke blankets for concealment. Use smoke blankets prior to assaults.

Sweep and clear operations to eliminate enemy forces acquiring our soldiers as targets. This is exceptionally effective in reducing or eliminating sniper activity and in breaching obstacles. However, your soldiers must be careful to avoid burning debris since this tends to reduce concealment.

Plan for enemy countermeasures. Enemy forces will counter your smoke use. Plan to intensify your counterreconnaissance and air defense efforts. The enemy may use countersmoke to confuse our command and control so avoid reliance on visual signals.

The enemy will increase use of indirect fire weapons when direct fire target acquisition is ineffective. Therefore, plan artillery counterbattery or countersmoke fire after crossing the LD/LC.

Reconnaissance must verify enemy locations. The enemy can use both our smoke and theirs to conceal movement to alternate positions or to break contact. Aggressive reconnaissance before and during the engagement will allow you to shoot and remain in contact.

Understand that smoke compresses the battlefield by limiting visibility. Smoke drastically reduces engagement ranges. Training your soldiers to operate in smoke reduces the degradation caused by smoke. It also reduces psychological impact on troops such as confusion, fear, and isolation. The Israeli Army successfully used phosphorous rounds in Beirut to screen their forces and isolate the enemy (enemy forces tended to congregate in the city). The use of smoke produced enemy casualties and generated the psychological effects of fear and isolation.

Urban terrain causes smoke streamers to break up quickly, creating the uniform phase closer to the smoke source. You can place smoke sources closer to target areas.

Ensure the entire squad, section, or platoon uses the smoke simultaneously to preclude drawing attention to a lone vehicle or element.

Smoke pots and smoke grenades are effective for concealing movement of small units. An example of an employment scenario follows:

*Squad members come under fire from snipers in upper floors. They use a grenade launcher to fire smoke and HE rounds into upper floors, blinding enemy observation. They emplace HC smoke pots or several smoke hand grenades downwind of and in between themselves and the target area or building. Concealed by the smoke, they maneuver to assault the target. Upon reaching the target area, they cease to make smoke to allow them to operate undegraded.*

Start the smoke mission prior to operation start time and continue well beyond the end of the operation. For example, you have planned a canal crossing for 0500 to 0700 hours. Start smoke at 0400. Stop smoke at 0800 to confuse the enemy as to the exact crossing time and size of the force.

Built-up areas nearly always have civilians/noncombatants occupying them. When planning the type of smoke weapon system, and you suspect noncombatants are present, give consideration to the lethality of the system before employment. For example, artillery-delivered smoke is useful around the periphery of a city. However, you should switch to less devastating systems in the center of the city, such as smoke munitions from grenade launchers, smoke pots, and smoke hand grenades.

Smoke units are extremely vulnerable in urban areas due to smoke generator signature. In addition, stationary smoke positions need to be closer to the target than over other terrain, bringing smoke generator elements within range of enemy small arms weapons. Mobile smoke systems are best. Stationary smoke systems make large volumes of smoke but require additional security support. Employ smoke generator vehicles in groups of three, with two vehicles making smoke and one vehicle overwatching.

## Deserts

There are three types of deserts:

- Rocky plateau deserts.
- Sandy or dune deserts.
- Mountain deserts. (Munitions effectiveness for mountain deserts is the same as for any mountainous region except that the considerations of snow are usually not applicable.)

It is important to recognize the specific terrain of each, because munitions effects will vary according to desert type. Desert battles tend to be more centralized. Brigade and battalion commanders often personally coordinate the interaction of maneuver and firepower. Engagements are often fought at long ranges.

In rocky plateau deserts, projected smoke and illumination rounds may be degraded by high winds, but may be used to silhouette the enemy. HE/PD is extremely effective, creating extra shrapnel by splintering rocks. FASCAM is very effective and should be employed with smoke and the natural terrain to force the enemy into unnavigable terrain.

In sandy or dune deserts projected smoke and illumination rounds are effective and can be used to silhouette the enemy. HE, PD, ICM, FASCAM, and delay are smothered by deep sands, making them ineffective.

Location determination is often very difficult in rocky plateau and sandy or dune deserts. Maps are often inaccurate, dunes shift, and heat waves hamper distance estimations. The Israelis help forward elements determine their own location by using artillery survey teams at two or more points, putting searchlights on those points, and, upon request, shooting a beam of light into the air. The forward observer can then shoot an azimuth to the beams of light and perform a map resection. The beam of light must project straight up, and the observer must shoot an azimuth at the lowest visible point on the beam. With this system, pyrotechnics may

also be shot into the air. The use of marking rounds as discussed for jungle operations also can help forward units self-locate.

Laser range finders must be used, especially when heat waves degrade distance estimating by conventional means. Observers can detect targets by observing dust clouds created by moving enemy forces. Employ smoke behind the enemy to silhouette them. The similarity of colors in the desert makes specific targets hard to spot. At night, illumination rounds burning on the ground behind the enemy have the same effect.

Usually, air observation is highly productive; however, the absence of landmarks in some areas degrades this capability. This problem is enhanced because aerial observers tend to see the battlefield in a two-dimensional perspective.

Lack of trees and hills makes aircraft more vulnerable to enemy air defenses. Use smoke to force enemy aircraft to fly higher, making acquisition easier. Radars are highly effective in the desert. Use them to aid in adjusting smoke onto targets.

Use smoke to—

- Complement ICM and FASCAM for obstructing and denying enemy use of roads.
- Silhouette the enemy, complement illumination fire at night, and increase the background contrast for sensors to acquire targets.

Priority targets for HC and WP smoke munitions and for generator smoke are likely enemy OPs, ATGM systems, and enemy air defense systems.

## Winter Zones

The extreme weather conditions in arctic and subarctic regions are dramatic and severely impact on observation, mobility, and delivery of fire. Specific weather phenomena with which the smoke and fire support personnel must be concerned include whiteout, greyout, and ice fog.

**Whiteout.** The observer appears to be in a uniformly white glow.

Neither shadows, horizon, nor clouds are discernible. The sense of depth and orientation is lost. Only very near, dark objects can be seen. Whiteouts occur over an unbroken snow cover and beneath a uniformly overcast sky. Blowing snow can cause the same effect.

**Greyout.** This is similar to whiteout except the horizon is distinguishable under greyout conditions. It occurs over a snow-covered surface during twilight conditions or when the snow is close to the horizon. There is an overall greyness to the surroundings. When the sky is overcast with dense clouds, there is an absence of shadows, resulting in a loss of depth perception.

**Ice fog.** This is common around inhabited areas during cold weather below 35 degrees Fahrenheit. Water vapor created by humans and vehicle exhausts may appear around soldier and equipment concentrations. Ice fog obscures vision and discloses locations by presenting a visible cloud to the enemy.

In winter zones, HC smoke and generator smoke are effective, and colored smoke may be used to silhouette the enemy. However, some of the canisters may be smothered in the deep snow. WP is effective; however, phosphorus may burn undetected in the snow for up to three to four days and may be a hazard to friendly troops subsequently moving through the area. HE/PD, HE/delay, ICM, and FASCAM are ineffective in deep snow. At least 40 percent of the blast from these munitions is smothered by the snow.

Weather and terrain conditions cause disorientation; changing terrain and poor maps make self-location difficult. Use marking rounds or searchlights and pyrotechnics from surveyed positions to help observers and smoke control officers orient themselves. Bright sunlight reflecting off snow-covered landscape causes snow blindness. Amber filters on binoculars and ob-

servation devices reduce the incidence of snow blindness.

Use of laser range finders is extremely critical because of lack of depth perception due to weather and terrain conditions. Use limited visibility positions to prevent degrading these systems. Use aerial observers because they can see deep and are not as prone to disorientation as are ground observers. Frequent poor weather reduces availability of CAS. Plan smoke use from CAS aircraft during windows of opportunity for good weather.

## NBC Conditions

The physiological and psychological effects of NBC conditions impact on all elements of combat power. These conditions, documented in FM 3-100, create special problems when either the enemy or friendly force use smoke and obscurants. Encapsulation in full, individual protective equipment significantly reduces a soldier's ability to—

- **See.** Peripheral vision and visual acuity are restricted. Observers and smoke control officers are not able to accurately judge smoke on target

or to estimate ranges for adjustments.

- **Hear.** Hearing is degraded. This is a significant problem on certain terrain, such as jungles, where fire and smoke are adjusted by Sound.

- **Communicate.** Communication is more difficult, as speakers and listeners often perceive that they cannot enunciate or hear as well. This has significant impact on adjusting fire or positioning smoke units.

- **React to stress.** Sustained operations are much more difficult, as encapsulation severely taxes human bodies. Leaders are at the greatest risk of combat ineffectiveness.

## Deception

Employed smoke draws attention to the area it covers. This characteristic makes smoke use significant in supporting the deception story. However, never plan to use smoke by itself for deception.

Tactical deception draws the enemy's attention from the area of the main attack. The object is to make the enemy commit forces to the deception and not the main attack.

Smoke supports tactical deception operations by—

- Drawing attention to the deception activity.
- Limiting the enemy's ability to identify the deception for what it is: a ruse, feint, or demonstration.

- Protecting the force performing the deception.

- Making two-dimensional decoy material look real.

Planners must provide enough resources so that smoke support for the deception mission lasts as long as the deliberate mission. The key to a successful smoke deception is to make the enemy believe that the smoke support is for the main effort. However, smoke support for the deception force should not be so large that it divides or degrades the effectiveness of support for the main effort.

Plan to attack the deception target just as you would in any other operation. The standard battlefield applications of smoke—screening,

obscuring, protecting, or marking—all apply. Use smoke to obscure, screen, protect, or mark a dummy or imaginary tactical smoke target area. Both the deliberate and deception mission should have the same visibility requirement and resources. Plan to use projected smoke extensively.

Planning considerations include—

- Ensure you place smoke on similar targets for both the main effort and deception. Deception and main effort smoke target areas should be similar in size.

- Shift smoke assets to the main effort only when assaulting the objective and when immediate smoke is required to protect an element of the main effort.

## Chapter 6

# Sustainment Planning

Sustainment planning for smoke use in tactical operations must focus on the sustainment imperatives: anticipation, integration, continuity, responsiveness, and improvisation. There are several critical factors planners must consider to sustain smoke support in any given operation:

- Number and types of smoke delivery systems and the quantity of available resources.
- The commander's priorities for support.
- consumption factors of the delivery system and large-area smoke assets for the type of operation you are planning.
- Critical smoke delivery systems, whose continuous operation is crucial to the battle's success.
- Major tactical contingencies such as exploitation, pursuit, and withdrawal.
- Real estate management (for example, the location of delivery systems and combat service support [CSS] assets). This involves resolving conflicts in unit/base positions of several units in the same area or sector.

Commanders and their planners must plan to sustain all smoke delivery means that are in their tactical plan. Planners must consider the following:

- Plan for continuous support.
- Forward positioning of essential CSS, such as ammunition and petroleum, oil, and lubricants (POL). Execute this at night if pos-

sible. Artillery and mortar basic loads of smoke ammunition are limited. If your plan calls for sustained projected smoke, you may need to pre-position ammunition forward to sustain the operation.

You may also want to pre-position smoke pots or WP main gun rounds.

- Use preplanned or preconfigured push packages (LOGPAC) of essential items. For missions where smoke requirements exceed existing assets, the commander should consider tailoring the LOGPAC to obtain the required items of ammunition or fuel.

- Plan for rapid resupply. If pre-positioning is not possible, plan to rapidly resupply artillery and mortar units. Configure ammunition in the ammunition supply point (ASP) for rapid sling load or truck transport to user units. Coordinate with the division or corps support command for dedicated transportation assets for a specific period of time to support the operation.

- Upload as much materiel as possible on unit transportation assets. Use existing assets to carry specific mission needs, and down load items that can be brought forward later.

- Plan real estate management. Ensure the pre-positioned stocks and the terrain around these stocks are earmarked for the user unit. The division support command (DISCOM), corps support command (COSCOM), or area support group (ASG) is the focal point for resolving conflicts in unit/base positions.

- Plan direct delivery from supply to user. When you expect very high rates of ammunition or POL consumption, coordinate for direct delivery from the COSCOM CSS asset to the user unit. This requires intensive coordination to ensure transportation assets are in place at the critical time, as well as coordination for delivery locations.

Chemical companies, smoke generator companies, and platoons in particular do not have sufficient organic logistics assets to sustain combat operations. Because of this, chemical units heavily rely upon the supported unit for CSS. When organized under a chemical battalion or brigade, the parent headquarters acts as an intermediary between the chemical company and the division or corps support command for sustainment support.

Both the chemical unit and the supported unit conduct planning to sustain large-area smoke. Planning for smoke operations must ensure the smoke element has the following:

- Maintenance, supply, and recovery support (fixing and supplying).
- Transportation assets available (transporting).
- Tactical resupply of Class III (for example, fog oil, packaged POL, and MOGAS) (fueling).
- Sufficient personnel (manning).
- Fire support, to include tactical resupply of Class V, and security (arming and protecting).

# Maintenance, Supplies, and Logistics

Smoke generators are very limited in number on the battlefield. Smoke generators are also resource-intensive items of equipment. Chemical brigades and battalions do not have a support platoon to manage, pick up, and deliver supplies. Chemical units, and smoke units in particular, are very dependent upon the supporting CSS structure to configure and deliver "push" packages of supplies. Appendix E outlines smoke sustainment planning guidance.

It is essential that commanders and planners consider logistical support for smoke units in the overall tactical plan for an operation. The plan must specify—

- Support relationship between the supported unit and the smoke unit.
- Which activities (TAACOM, COSCOM, ASG, support group, DSA, BSA, or field trains) provide what type(s) of support for the smoke unit:
  - Class I, II, IV, VI, and VII.
  - Class III package (fog oil and other packaged POL).
  - Class III bulk (MOGAS, diesel).
  - Class V (small arms, mines, grenades, and explosives).
  - Class VIII and general medical support.
  - Class IX intermediate level maintenance support, less smoke generator specific parts.
- Consumption rates for the specified mission such as amount of fog oil and other POL needed to sustain smoke operations.
- "Push" packages to support committed units (for example, delivery times and locations, quantities, and frequency).
- Transportation support:
  - Availability of transportation assets.
  - Preplanned deliveries to provide the "push" package.
- Priorities for support of units or areas.

## Supporting Units

The smoke unit commander specifies the items for inclusion into a "push" package. The CSS unit specified in the plan will configure supplies for rapid distribution to the smoke unit. Normally, support to smoke units is on an area basis. When providing this support, support units use varying combinations of unit distribution such as long-range patrol (LRP) and supply point distribution procedures.

Unit distribution is the preferred method for resupplying smoke units. The supporting unit delivers supplies to the smoke unit's area using preplanned or dedicated transportation assets. The supporting unit generally arranges this transportation, although the transportation assets may be dedicated to resupplying the smoke unit for a particular mission only. The supporting unit should plan for throughput whenever possible.

An alternate means of resupply is supply point distribution. The supporting unit issues supplies from a supply point to the smoke unit. The smoke unit uses its own limited transportation assets to move the supplies to its area of operations.

When determining the type of distribution to be used to support smoke units, logistics planners at all levels should consider—

- Availability of personnel and equipment to deliver and pick up supplies.
- Missions of the supported forces.
- Adequacy of road networks in the area of operations.
- Priorities for use of the roads.
- Anticipated distances between supporting and supported forces.
- Locations of the supported forces.
- Threat to road and rail networks.

## Basic Load

Basic load is the amount of equipment and supplies required by a unit to sustain itself until resupply

can be effected. The basic load is approved by the commander. The basic load is not a fixed quantity; it may be altered as situations dictate. For example, a smoke unit conducting a prolonged smoke operation may have its basic load of smoke pots increased for that particular operation.

One method of easing the resupply requirements of smoke units is tailoring of the basic loads. Extended smoke operations away from the main force can be given larger or different basic loads of fuel, parts, or other necessary supplies. Use the consumption tables in Appendix E as a guide for preparing unit basic loads.

## Fog Oil Resupply

Fog oil is a packaged POL product arriving in 55-gallon drums. Support units can bulk fog oil by transferring the fog oil from the 55-gallon drums to fuel pods or tank and pump units. The fog oil used in smoke operations comes through the corps and division support areas. It may be delivered as far forward as the brigade support area by the supporting CSS unit. From here the smoke unit's fuel supply elements pick up the fog oil. Based on the type and duration of the smoke mission, the fuel supply element either establishes a forward fuel supply point or keeps stocks uploaded on organic vehicles. For rear area missions the smoke-fuel supply point may be supported from existing Class III or other supply activities.

There are two methods for fog oil resupply on-line resupply and off-line resupply.

**On-line resupply.** Stationary smoke points are resupplied on line during a smoke mission. This requires the fog oil and MOGAS resupply squad to move to each point as needed. The resupply squad or section will move tank and pump units (TPUs) to the line,

drop the drums of fog oil at the smoke point, or pre-position drums at a follow-on smoke point. This increases the vulnerability of the

resupply squad or section and the smoke point.

**Off-line resupply.** Mobile units are resupplied by rotating individual systems through a fuel resupply point

1 to 2 kilometers to the rear of the smoke line. You can also resupply stationary units that are displacing in this manner.

## Fire Support and Security

When planning for the use of smoke in support of combat operations, it is essential commanders and operational planners recognize the vulnerability of smoke units. Smoke generator units conducting smoke operations leave a very recognizable signature on the battlefield. Smoke by its very essence attracts attention. An observer only needs to follow the smoke streamer to its source to target the individual smoke-producing device. Smoke generator operators and smoke unit commanders are acutely aware of this and utilize every measure available to reduce this signature.

Some of these steps include -

- Making maximum use of natural cover and concealment.
- Using reverse slope positioning.
- Using self-protecting smoke (for example, smoke pots upwind of generator positions).
- Continuously moving mobile systems within designated areas to minimize effective targeting.
- Staggering positions of generators.
- Digging in or hardening.
- Making smoke from flanks and stand-off positions whenever possible.

While the above actions will enhance the smoke unit's survivability, proper employment by the supported unit is essential. As an example, mechanized smoke systems provide some small-arms protection

for the crew and are less vulnerable to indirect fire than wheeled smoke systems.

Lessons learned at the NTC consistently demonstrate that mechanized smoke systems suffer high-loss rates when they are among the lead elements of armored assaults. While improper employment at the NTC serves as a valuable training aid for commanders, the same mistake in combat will result in the loss of a significant and scarce combat multiplier.

Reconstitution of battlefield losses will be slow. They may not occur at all based on the availability and priority of distribution for such a limited asset. In a rapidly moving armor assault, the commander may wish to plan for additional smoke support from his indirect fire artillery using WP or HC smoke projectiles integrated into preparatory fire. This fire placed on or in front of the objective may accomplish the desired result and not expose mechanized systems to unnecessary risk.

### Fire Support

Supporting smoke assets coordinate with the supported unit for fire support.

Fire support is based on artillery availability and the coordination that takes place among the smoke unit, chemical staff office, S3/G3,

and FSO. Integrate the smoke unit fire plan with the supported unit fire plan. Fire support planning must consider—

- Priorities of fire support.
- Availability of smoke rounds (mortar and artillery).
- Named areas of interest (NAI) and target areas of interest (TAI) of the maneuver unit.
- Coordination with fire support assets for the primary, alternate, and supplemental smoke operations areas or points.
- On-call targets (nominated by the smoke unit).

### Security

Plan for the security for smoke units based upon availability of the supported unit's assets and priorities. When security forces are provided for smoke assets, coordination measures include -

- Determining needed duration of security support.
- Determining size of security element.
- Locating overwatch positions for security elements.
- Determining smoke and security element leaders understand the commander's concept, fire support plan, and communication procedures, and are aware of smoke tactical resupply locations.

Smoke support occurs in many types of terrain under different weather conditions. Operations may occur in NBC-contaminated areas. Leaders balance mission requirements against protection require-

ments. They consider visibility constraints and heavy work rates during smoke missions. Specifically, it is difficult to see in smoke. It is more difficult to see in smoke when in full individual protective equipment

(IPE). Heat buildup becomes critical to the welfare of the soldier. This is especially true when the operator of the M157 smoke generator set is "buttoned-up" inside the M1059 mechanized smoke gener-

ator in full IPE in support of a mechanized or armored division.

Smoke generator crews may be difficult to replace in future conflicts. Therefore, you must focus on maintaining the available force at peak combat effectiveness. Leadership is the key to maintaining the strength and spirit of the fighting force. Leaders must assemble, transport,

and distribute their units as the commander requires in his task organization, yet conserve their fighting strength. Leaders must give special consideration to—

- Health services.
- Administrative support.
- Morale and welfare activities.
- Discipline.
- Stress management.

- Replacement planning.

Limited visibility has a significant impact on sustainment operations. It increases the time and decreases sustainment responsiveness. Support and smoke units should thoroughly rehearse sustainment activities prior to execution of the plan.

## Chapter 7

## VISUAL-INFRARED OBSCURANTS

Today virtually every nation and non-state organization has access to—

- advanced tactical sensors for target acquisition (thermal imagers) and intelligence gathering surveillance systems (ground and air reconnaissance).
- precision-guided munitions delivered by artillery, missiles, and aircraft that operate in the IR region of the electromagnetic spectrum.

These capabilities are available through internal manufacturing or purchase on the world market.

These thermal imaging sights allow them to acquire and engage targets through visual smoke, at night, and under adverse weather conditions. To counter the increasingly sophisticated sensor threat, the M56 and M58 smoke generator systems provide maneuver commanders the capability to control and dominate the visual through far infrared (IR) portions of the electromagnetic spectrum using visual (fog oil) and infrared (graphite) obscurants.

### VISUAL-INFRARED OBSCURANT GENERATOR SYSTEMS

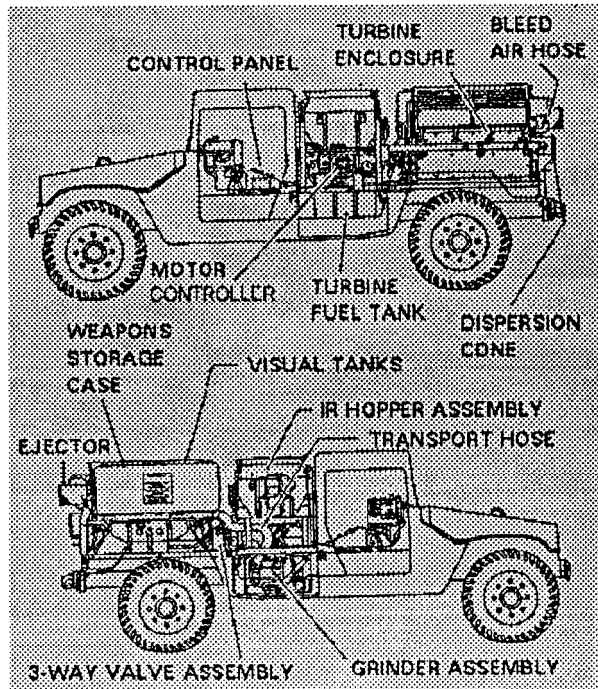

Figure 7-1. M56 Smoke Generator System.

The M56 Smoke Generator System (Figure 7-1) mounted on an M113 HMMWV is organic to motorized smoke units and dual-purpose smoke/decontamination units. The M56 can produce 90 minutes of visual/near infrared obscurant and 30 minutes of infrared obscurant without resupply. This system can produce obscurants while mobile or stationary.

The M58 Smoke Generator System (Figure 7-2) mounted on the M113A3 APC is organic to mechanized smoke units. The M58 can operate mobile or stationary. It can produce 90 minutes of visual/near infrared obscurant and 30 minutes of

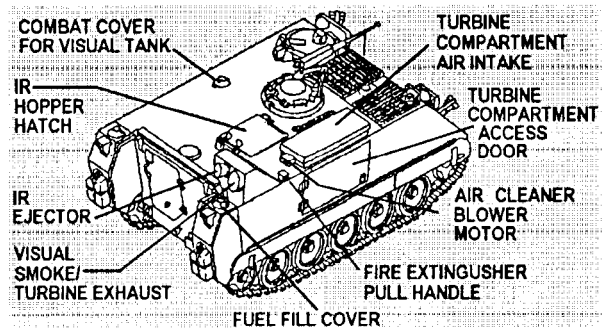

Figure 7-2. M58 Smoke Generator System.

infrared obscurant without resupply. Chassis improvements allow the M58 to keep pace with mechanized and armor units. The systems are equipped with a driver's thermal imager and an NBC contamination particulate filter unit.

Each system can selectively produce visual obscurants (vaporized fog oil) to defeat acquisition in the visual, and near infrared and infrared obscuration (graphite flakes) to defeat target acquisition devices that operate in the mid and far infrared. The two obscurants may be employed simultaneously or separately. If employed simultaneously, the threat force's capability to acquire targets with day sights and thermal imagers will be degraded. If employed separately, the visual obscurant will degrade day sights and the IR obscurant will degrade the thermal imagers.

### OBSCURANT EFFECTS ON SENSORS/SEEKERS

Visual and infrared obscurants have distinctly different effects on friendly and threat force sensors.



Therefore, commanders and staffs must understand the opportunities and limitations associated with each. Employment of infrared obscurants is a double-edged sword. A maneuver commander may want the added concealment offered by an infrared obscurant (graphite), but must accept the fact it will also degrade his own systems. Commanders and staffs must identify the threat sensor/seeker systems to be countered, determine the obscurant to be employed, and identify impacts on their own systems. Table 7-1 depicts the types of sensors and seekers found on today's battlefields and the relative degree of degradation caused by various natural and man-made obscurants.

### VISUAL-INFRARED OBSCURANT CONCEPTS

Intelligence preparation of the battlefield (IPB) determines how the threat arrays sensors and seekers on the battlefield. After the IPB process has been accomplished, the chemical battle staff develops a

plan to integrate smoke and obscurant assets into the operational plan. The goal of the obscurant plan is to defeat critical threat sensors and seekers. For example, the IPB process has determined that the threat possesses a significant thermal imagery capability located with his reconnaissance assets. The smoke plan would likely focus on employing IR obscurants whenever and wherever the threat might attempt to utilize his reconnaissance assets.

The doctrine for IR obscurants is different from the doctrine for visual obscurants. IR obscurants provide the capability to defeat a significant threat asset—thermal imagers. Visual obscurants are used primarily to provide force protection from a threat having limited electro-optical capabilities such as first generation FLIR or with an even lesser capability such as systems that can only operate in the visual region of the electromagnetic spectrum. Overall, IR obscurants will be employed directly on the threat or between the threat and friendly forces. Visual obscurants are employed on friendly forces to provide

Table 7-1. Sensors and Seekers.

		DAY SIGHT	IMAGE INTENSIFIER	LASER	THERMAL IMAGERS	MMW						
<table border="1"> <tr> <td>Fog oil, HC TA, TiO<sub>2</sub>, phosphorus</td> <td>M157/M1059, M56/M59, LVOSS, LB, M62, M19, M825, M884, M8</td> </tr> <tr> <td>Graphite Brass</td> <td>M56/M58 M76, M81</td> </tr> <tr> <td>Graphite</td> <td>M56/M58 F31 M81</td> </tr> </table>	Fog oil, HC TA, TiO <sub>2</sub> , phosphorus	M157/M1059, M56/M59, LVOSS, LB, M62, M19, M825, M884, M8	Graphite Brass	M56/M58 M76, M81	Graphite	M56/M58 F31 M81	Visual Obscurant	MAJOR	MAJOR	MAJOR	MINOR	MINOR
	Fog oil, HC TA, TiO <sub>2</sub> , phosphorus	M157/M1059, M56/M59, LVOSS, LB, M62, M19, M825, M884, M8										
	Graphite Brass	M56/M58 M76, M81										
	Graphite	M56/M58 F31 M81										
	IR Obscurant	MODERATE	MODERATE	MAJOR	MAJOR	MINOR						
	MMW Obscurant	MINOR	MINOR	MINOR	MINOR	MAJOR						
	Heavy Dust	MODERATE	MODERATE	MAJOR	MINOR	MINOR						
Heavy Fog	MAJOR	MAJOR	MAJOR	MODERATE	MINOR							
Heavy Precipitation	MAJOR	MAJOR	MAJOR	MODERATE	MODERATE							

**DEGRADATION**

- MAJOR
- MODERATE
- MINOR

protection while still allowing for the ability to maneuver within the obscurant cloud.

### Offense

Employment of an infrared obscurant in offensive operations gives the maneuver commander an additional element of combat power. IR obscurants are able to defeat threat sensors and seekers. Two missions should be considered. One is to utilize the IR obscurant as a screen to prevent thermal ground sensors from detecting and identifying friendly forces. Another is to utilize the IR obscurant to obscure threat sensors. In this mission, given favorable weather conditions, the smoke plainer would employ the IR obscurant directly on the threat sensors.

### Defense

IR obscurants in the defense will provide protection from smart weapons and prevent those weapons from acquiring their targets. Although the employment of IR obscurants reduces the friendly ability to maneuver, the commander may choose this option to increase the survivability of his forces in the event that other resources are unavailable to defeat the threat's smart weapons. For example, IR obscurant would provide considerable protection from smart weapons for rear area operations such as port facilities, logistical sites, and airfields.

### Cloud Dynamics

Infrared obscurants are subject to the same weather and terrain considerations as visual obscurants. For planning purposes, the IR obscurant cloud will travel approximately the same distances as a visual cloud and will cover the same size target area. Visibility criteria in terms of *haze*, *blanket*, and *curtain* are not true for IR obscurants. Infrared clouds are defined in terms of transmittance value in relationship to percentage of probability of detection. Given wind speed, source strength, and downwind distance (Annex H), chemical staffs are able to estimate probability of friendly forces being detected when screened or protected by infrared obscurants.

### Smoke Control

Generally, smoke control is the function of the smoke platoon leader or the smoke company commander under the direction of the maneuver commander, a breach or river crossing site commander, or a facility commander. Smoke control procedures will be

essentially the same for visual and infrared screens. However, at *night*, actual observation of the infrared cloud requires a thermal viewer. Without an IR sensor, smoke control officers will rely on the fog oil cloud to adjust target coverage or on information provided by the supported maneuver unit.

### Coordination Measures

Infrared obscurants offer additional options to the commander: visual only, IR only, or visual/IR obscurants. The chemical battle staff must assist the commander in recommending the appropriate type obscurant based on IPB. Limiting factors may be based on planned friendly activity, the need to prevent signaling a friendly presence to the threat force, or danger inherent to friendly operations that might result in increased fratricide.

### Smoke Control Graphics

Smoke target numbering systems and graphic control techniques will be increasingly important as commanders and staffs come to rely more heavily upon digitization. Battle staffs will maintain electronic overlays of planned smoke missions (similar to trafficability overlays) to allow for coordination of mission planning with adjacent and higher organizations. With the fielding of large-area infrared smokes, graphic control aids must be developed to portray *no smoke* areas, *visual only* smoke targets, *visual-infrared* smoke targets, and *infrared only* targets. Target numbering procedures should be standardized to enable adjacent units to recognize immediately smoke missions that may adversely affect their operations due to wind shifts, the cloud traveling farther than anticipated, or flank units perhaps being silhouetted. Although subject to local SOPs, visual only smoke target numbers should begin with a V followed by five digits. IR only smoke target numbers should begin with IR followed by four digits. Visual-infrared target numbers should begin with VIR followed by three digits.

### Troop Safety

The same masking requirements and procedures for fog oil employment apply for infrared (graphite) obscurants. Overall, carry the mask when participating in operations that include the use of infrared obscurants. Mask when passing through or operating in a dense cloud. If duration of exposure will exceed 4 hours or breathing difficulties occur, masking is required.

### LOGISTICAL SUPPORT

Logistical support for chemical smoke units requires special consideration with the addition of infrared smoke material (graphite). One 5-ton truck is capable of carrying the weight (and volume) of 9 barrels of fog oil and up to 4,350 pounds of IR obscurant simultaneously. If two 5-ton trucks are used to resupply 6 generators, the travel time to a supply point, reloading with fog oil and IR obscurants, and returning to the mission site must not exceed 75 minutes. When consecutive infrared missions are desired to support maneuver operations, the chemical staff with the G4/S4 anticipates resupply requirements and ensures that the smoke plan is supportable. Use the consumption table (Table 7-2) as a logistical planning tool for visual infrared smoke operations. Planners should keep in mind the M56 and M58 smoke generator systems have a variable setting capability for both IR (graphite) and fog oil modules. This allows the operator to control the rate graphite and fog oil is consumed. For example, at a

consumption rate of 5 pounds per minute, the system can produce 1 hour of IR obscurant. If the consumption rate is 10 pounds per minute, the system can produce 30 minutes of IR obscurant.

### CONCLUSION

The M56/M58 smoke generator systems provide commanders and staffs an additional element of combat power. IR obscurants in any operation can be employed to *protect* the force, *screen* friendly maneuvers, or to *obscure* and attack threat sensors and seekers. IPB is critical in planning infrared missions by identifying threat sensors and seekers and how they are arrayed in theater. The chemical battle staff, by participating in the IPB process, war gaming, and rehearsals will facilitate an effective obscurant plan to support the commander's intent. The IPB process, focusing on how the threat arrays his sensors and seekers on the battlefield, are critical steps in planning the employment of IR obscurants.

Table 7-2. Consumption Table.

**CONSUMPTION TABLE**  
M56 / M58 SMOKE GENERATOR SYSTEM

COMPONENT	1 HR	2 HR	6 HR	24 HR	48 HR
GAS TURBINE ENGINE (12 gal/hr)	12	24	72	288	576
VISUAL SMOKE MODULE ( 1.33 gal/min)*	80	160	479	1915	3830
IR MODULE**	600	1200	3600	14,400	28,800

\* FOG OIL CONSUMPTION IS BASED ON MAXIMUM VARIABLE SETTING.

\*\* IR OBSCURANT MODULE IS FED AT A VARIABLE RATE FROM 5 TO 10 lbs/min. CONSUMPTION IS BASED ON MAX SETTING.

M56 CAPACITIES: FOG OIL TANK 120 gal, IR MODULE 300 lbs, GAS TURBINE ENG 26 gal.

M58 CAPACITIES: FOG OIL TANK 120 gal, IR MODULE 300 lbs, GAS TURBINE ENG 95 gal.

## Appendix A

# Smoke Planning

Chapter 1 describes the general considerations for planning smoke support. This appendix provides procedures for preparing smoke planning documents and gives some examples. The smoke planning document examples include a smoke es-

timate format (Figure 11), smoke target list work sheet (Figure 12), and a smoke annex format (Figure 13). In addition, Figure 14 shows a coordination checklist for chemical unit commanders to use when they receive orders for a smoke mission.

Chemical staff officers must coordinate all smoke support with the G3/S3, FSCoord, and lateral units. These planning document examples contain several mechanisms to help staff officers verify such coordination.

## Target Analysis Procedures

Coordinate with the commander or G3/S3 to determine obscurant requirements for the unit. Coordinate with the FSO, and nominate targets for obscuration. Identify targets within the FSO's capability. Also identify targets not within the FSO's capability.

Record targets on the target list work sheet.

Identify smoke delivery means to support the operation:

- Smoke generator unit(s).
- Mortars.
- Maneuver combat vehicles.
- Field artillery unit(s).

- Close air support assets.
- Naval gunfire.
- Other delivery means.

Plan targets, to include the following considerations:

- Which delivery means to use. For guidance, see the employment matrixes.
- Which obscurant to use. For guidance, see Appendix B, Figure 16, page 73.
- Duration of smoke on each target.
- Time to fire or make smoke.

Coordinate with the G3/S3 for the final target list and schedule of

smoke engagement with other than fire support assets.

Coordinate with the FSO for the final target list and schedule of fire. Designate the person, event, or time that will initiate the smoke mission. Coordinate with adjacent units, and check weather conditions.

Add or delete smoke missions on the basis of available assets and weather and terrain factors. Coordinate with any adjacent units not previously affected, but which may now be affected by smoke.

Prepare the smoke support annex to the OPLAN/OPORD.

## Planning Documents

### Smoke Estimate Format

After receiving the restated mission and planning guidance from the commander, the chemical officer prepares a smoke estimate (Figure 11).

### Smoke Target List Work Sheet

Mandatory entries in a smoke target list work sheet include —

- **Smoke target number.** Assign a control number to identify the smoke target. The smoke control number contains five characters. The first character is a letter; the following four are numbers. A local SOP will establish how to assign these numbers. They are not the tar-

get number for fire support purposes. Fire support target numbers may be recorded in the remarks column. Smoke target numbers are five characters in length. The first character is a letter; the final four are numbers. Divisions and higher field headquarters may assign a specific group of numbers to organizations (for example, 1st Bde is A1001 through A1999; 2d Bde is B2001 through B2999). These numbers provide the chemical staff officer with a brevity code for smoke

- **Target description.** Write a brief description of the target (for example, combat reconnaissance patrol).
- **Target location.** Enter the center of mass UTM grid coordinates for the target.
- **Size.** Give the dimensions of the target in meters.
- **EO system.** This is the system you will attack with smoke/obscurants.
- **Delivery means.** Identify potential delivery means for the smoke.
- **Type of smoke.** Identify the type of smoke/obscurant to employ.

Use the seven employment matrixes (Tables 4 through 10, pages 65 through 71) to determine

- **Priority.** This is the priority of attack based on fire support's target value analysis.
- **Remarks.** Self-explanatory.

### Smoke Annex to OPLAN or OPOD

The smoke annex to a plan or order implements the commander's decisions concerning how to use smoke in the **operation**. The chemical staff officer prepares and coordinates the smoke annex. He or she, as a minimum, provides copies to subordinate and adjacent units (if affected by the smoke), the

## Employment Matrixes

the appropriate delivery means for specific smoke targets. The tables cover general, hasty attack,

G3/S3 and G4/S4 officers, FSCOORD, and smoke unit leaders.

### Smoke Mission Coordination Checklist

Smoke unit commanders or leaders use this checklist to verify coordination with the supported unit and any adjacent units that might be affected by the smoke. The chemical staff officer provides most of the information (such as visibility criteria and target location); but, the smoke unit leader must personally finalize coordination, whenever, possible.

deliberate attack, defense, retrograde, special operations, and MOUT situations.

CLASSIFICATION

Copy \_\_\_ of \_\_\_ Copies

Issuing Headquarters: \_\_\_\_\_

Date-Time Group: \_\_\_\_\_

Message Reference Number: \_\_\_\_\_

**SMOKE ESTIMATE**

References: Map, charts, smoke overlays, and relevant documents.

Time zone used throughout the order: \_\_\_\_\_

1. Mission. This is the mission statement from the commander's estimate.
2. The Situation and Courses of Action.
  - a. Considerations Affecting the Possible Courses of Action.
    - (1) Operations to be supported.
    - (2) Characteristics of the area of operations.
      - (a) Weather.
      - (b) Terrain.
      - (c) Other pertinent factors.
  - b. Enemy Situation. Include potential weaknesses we wish to exploit and nominate potential targets.
  - c. Own Situation. Include smoke production asset status.
    - (1) Tactical situation.
    - (2) Smoke assets (projected, generator, self-defense) availability.
    - (3) Personnel, logistics, and CMO.
      - (a) Smoke munitions.
      - (b) Fog oil.
      - (c) MOGAS.
      - (d) Smoke generator unit readiness.
      - (e) Available transportation support.

CLASSIFICATION

*Figure 11. Sample format for a smoke estimate. (Part 1 of 2)*

CLASSIFICATION

d. Anticipated Difficulties or Difficulty Patterns.

e. Own Courses of Action.

3. Analysis of Courses of Action. Analyze each in light of critical incidents, times, areas, and significant difficulties.

4. Comparison of Courses of Action. Evaluate deficiencies from a smoke delivery and target defeat perspective. List advantages and disadvantages including methods to overcome deficiencies.

5. Conclusions. Indicate if mission is supportable and which course of action best supports the mission.

(Chemical Officer)

Annexes (as required)

Distribution: Must include G2/S2, G3/S3, and FSO at a minimum.

CLASSIFICATION

*Figure 11 continued. (Part 2 of 2)*

### Smoke Target List Worksheet

Smoke Target No.	Target Description	Target Location (UTM Grid)	Size (in Meters)		EO System	Delivery Means	Type of Smoke	Priority	Remarks
			L	x W					

SAMPLE

Figure 12. Target list worksheet example.



CLASSIFICATION

Copy \_\_\_ of \_\_\_ Copies  
Issuing Headquarters: \_\_\_\_\_  
Date-Time Group: \_\_\_\_\_  
Message Reference Number: \_\_\_\_\_

Annex \_\_ (Smoke Support) to OPLAN (or OPORD)

REFERENCES: (Map, charts, smoke overlays, and relevant documents.)

Time zone used throughout the order (or plan): \_\_\_\_\_

1. SITUATION.

a. Enemy Forces. See Annex \_\_ (Intelligence) to OPLAN/OPORD No. \_\_\_\_\_. (Add any items identified in the smoke estimate but not included in the intelligence annex. Ensure you cover weather and terrain factors.)

b. Friendly Forces. (Include information concerning smoke assets, not covered by the operation order, that are available in higher, adjacent, supporting, and reinforcing units.)

c. Attachments and Detachments. (List assets supporting the smoke mission, attached to or detached from the issuing headquarters.)

d. Assumptions. (OPLAN only)

2. MISSION. (State the mission for smoke delivery means.)

3. EXECUTION.

a. Concept of Operation. (Describe the concept for employment of smoke assets, to include the commander's intent and support priorities. Cover the role of smoke in support of the deception plan.)

b. (In subsequent lettered subparagraphs, give the specific tasks to be accomplished by smoke assets.)

(1) Generator smoke. (List specific missions, targets, and tasks for smoke generator organizations.)

(2) Projected smoke. See Annex \_\_ (Fire Support).

(3) Other smokes. (List specific missions for units to use VEES, smoke pots, or other smoke production means.)

CLASSIFICATION

Figure 13. Sample smoke annex to an OPLAN or OPORD. (Part 1 of 3)

CLASSIFICATION

c. Coordinating Instructions. (State coordination or control applicable to two or more elements of the command.)

- (1) (Designation of smoke control officer.)
- (2) (Key person, time, or location to initiate smoke.)
- (3) (Smoke target list and overlay.)
- (4) (Schedule of smoke delivery.)

4. SERVICE SUPPORT

a. Material and Services. (Include information pertaining to availability; procedure for distribution; prestock points; and transportation of smoke munitions, bulk or packaged smoke generator fuels, and other supplies, to include—

● Which activities (TAACOM, COSCOM, ASG, support group, DSA, BSA, or field trains) provide what type(s) of support for the smoke unit:

- Class I, II, IV, VI and VII?
- Class III package (fog oil and other packaged POL)?
- Class III bulk (MOGAS, diesel)?
- Class V (small arms, mines, grenades, and explosives)?
- Class VIII and general medical support?
- Class IX intermediate level maintenance support, less smoke generator specific parts?

● Consumption rates for the specified mission (for example, amount of fog oil and other POL needed to sustain smoke operations).

● Push packages to support committed units (for example, delivery times and locations, quantities, and frequency).

● Transportation support:

- Availability of transportation assets.
- Preplanned deliveries to provide the push package.

● Priorities for support of units or areas.)

b. Miscellaneous.

CLASSIFICATION

*Figure 13 continued. (Part 2 of 3)*

CLASSIFICATION

5. COMMAND AND SIGNAL

a. Command. (State procedures for control of smoke assets and location of primary and alternate command posts.)

b. Signal. (CEOI reference.)

(Commander)

(Authentication)

ENCLOSURE (If operation overlay is enclosed, describe enclosure.)

DISTRIBUTION:

CLASSIFICATION

*Figure 13 continued. (Part 3 of 3)*

CLASSIFICATION

1. Grid coordinates of the smoke mission (target location): \_\_\_\_\_
2. Start and stop date/time/event of smoke mission:  
START Date/Time/Event: \_\_\_\_\_  
STOP Date/Time/Event: \_\_\_\_\_
3. On/off-station date/time for the smoke unit(s):  
ON-STATION date/time: \_\_\_\_\_  
OFF-STATION date/time: \_\_\_\_\_
4. Type of visibility in the smoke required: \_\_\_\_\_  
(Blanket: less than 50 meters.) (Haze: 50 to 150 meters.)
5. Enemy location(s)/activity: \_\_\_\_\_
6. Communications:
  - (a) Supported unit's frequencies and callsign:  
Primary Frequency: \_\_\_\_\_ Alternate: \_\_\_\_\_  
Callsign: \_\_\_\_\_
  - (b) Supporting unit's frequencies and callsigns:  
Primary Frequency: \_\_\_\_\_ Alternate: \_\_\_\_\_  
Callsign: \_\_\_\_\_
7. Supporting unit's command relationship to the supported unit (DS, GS, attached, OPCON):  
\_\_\_\_\_

CLASSIFICATION

*Figure 14. Sample smoke mission coordination checklist. (Part 1 of 2)*

CLASSIFICATION

8. Supported units' responsibilities to the supporting unit (for example, maintenance, transportation, fuel, and feeding): \_\_\_\_\_

9. Required staff coordination for the mission: (Check applicable staff sections.):

S2 \_\_\_ S3 \_\_\_ S4 \_\_\_ FSE \_\_\_ ALO \_\_\_ ENG \_\_\_

10. Location of supported unit's TOC: \_\_\_\_\_

11. Challenge, password(s), and code word(s): \_\_\_\_\_

12. Coordination effected with subordinate units, DATE/TIME: \_\_\_\_\_

13. Coordination effected with adjacent units, DATE/TIME: \_\_\_\_\_

14. Designate supply route(s) in/out of area: \_\_\_\_\_

15. Determine local weather conditions and peculiarities: \_\_\_\_\_

16. Determine any additional security requirement (for example, supporting unit requirement(s) for security forces): \_\_\_\_\_

17. Liaison information (between supported unit and supporting unit): \_\_\_\_\_

18. Smoke operation overlay: \_\_\_\_\_

19. After action report (AAR) to division NBCC: \_\_\_\_\_

Date/Time Mission Started: \_\_\_\_\_

Duration of Mission: \_\_\_\_\_

Fog Oil/ MOGAS Consumption: \_\_\_\_\_

Mission Issues/Problems: \_\_\_\_\_

Mission Results (success or failure): \_\_\_\_\_

CLASSIFICATION

*Figure 14 continued. (Part 2 of 2)*

Table 4. Smoke target matrix for general use.

Weapon Target	Artillery Smoke	Mortar Smoke	Smoke Pots	Smoke Generators	Smoke Hand Grenades	Smoke Rockets	Grenade Launchers	VEESS
Obscure Objective	X	X			A	X	X	
Conceal Breaching	A	A	X	X				
Conceal Movement	A	A	A	X	A		A	A
Blind Snipers	A	A			A	X	X	
Hide Vehicle From ATGM	A	A			X		X	X
Screen Bridging Operations	A	A	X	X	A	A	A	A
Segregate Enemy	X	X				A	A	
Support Deception	A	A	A	X				A
Screen Facilities			X	X				
Counter- smoke	X	X	A			X	A	

X = Primary System  
A = Alternate or Secondary System

Table 5. Smoke target matrix for hasty attack.

Weapon Target	Artillery Smoke	Mortar Smoke	Smoke Pots	Smoke Generators	Smoke Hand Grenades	Smoke Rockets	Grenade Launchers	VEESS
Obscure Objective	X	X		A		A	A	
Conceal Breaching	A	A	X	X		A		A
Conceal Movement	A	A	X	X	A		A	A
Blind Recon	X	X			A	X	A	
Hide Vehicle From ATGM							X	X
Screen Bridging Operations	A	A	X	X	A	A	A	A
Segregate Enemy	X	X			A	A	A	
Support Deception	A	A	X	X				A
Silhouette Enemy		X	A	A	A		A	
Isolate Enemy Aviation	X	A	A	A				

X = Primary System  
A = Alternate or Secondary System

Table 6. Smoke target matrix for deliberate attack.

Weapon Target	Artillery Smoke	Mortar Smoke	Smoke Pots	Smoke Generators	Smoke Hand Grenades	Smoke Rockets	Grenade Launchers	VEESS
Obscure Objective	X	X						
Conceal Breaching	A	A	X	X		A		A
Conceal Movement	A	A	X	X	A		A	A
Blind Recon	X	X			A	X	A	
Hide Vehicle From ATGM				A			X	X
Screen Bridging Operations	A	A	X	X	A	A	A	A
Segregate Enemy	X	X					A	
Support Deception	A	A	X	X				A
Silhouette Enemy		X	A	A	A		A	
Conceal Assembly Area			X	X			A	

X = Primary System  
A = Alternate or Secondary System



Table 7. Smoke target matrix for defense.

Weapon Target	Artillery Smoke	Mortar Smoke	Smoke Pots	Smoke Generators	Smoke Hand Grenades	Smoke Rockets	Grenade Launchers	VEESS
Silhouette Enemy	X	X	A			X		
Conceal Obstacles/ Emplacement			X	X				A
Conceal Movement	A	A	X	X	A	A	A	A
Blind Recon	X	X			A	X	A	
Hide Vehicle From ATGM			A	A	A		X	X
Isolate Enemy Aviation	X	A	A	A				
Segregate Enemy	X	X				A		A
Support Deception		A	A	X				A
Screen Facilities			A	X				
Counter- smoke	X	X				A		

X = Primary System  
A = Alternate or Secondary System

Table 8. Smoke target matrix for retrograde.

Weapon Target	Artillery Smoke	Mortar Smoke	Smoke Pots	Smoke Generators	Smoke Hand Grenades	Smoke Rockets	Grenade Launchers	VEESS
Obscure Positions	A	A	X	A		A		
Conceal Mobility Operations			X	X				A
Conceal Movement			A	X	A		A	X
Blind Recon	X	X			A	X	A	
Hide Vehicle From ATGM			A	A	A		X	X
Isolate Enemy Aviation	X	X	A	A				
Segregate Enemy	X	X	A		A	X	A	
Support Deception		A	X	X				A
Screen Facilities			A	X				A
Counter-smoke	X	A				X		
Isolate Pursuing Forces	A	A				X		
Silhouette Enemy	X	X	A			X		

X = Primary System  
A = Alternate or Secondary System

Table 9. Smoke target matrix for special operations.

Weapon Target	Artillery Smoke	Mortar Smoke	Smoke Pots	Smoke Generators	Smoke Hand Grenades	Smoke Rockets	Grenade Launchers
Obscure Objective	X	X		A	A	X	X
Conceal Breaching		X	A		A		
Conceal Movement				X	A	A	A
Blind Snipers	A	A			A	A	X
Conceal Infiltration			A		A	X	A
Screen Exfiltration			A		X		
Segregate Enemy	X	X				X	A
Support Deception	A	A	A	X	A	A	A
Screen Facilities			A	X			
Counter- smoke	A	A				X	

X = Primary System

A = Alternate or Secondary System

Table 10. Smoke target matrix for MOUT.

Weapon Target	Artillery Smoke	Mortar Smoke	Smoke Pots	Smoke Generators	Smoke Hand Grenades	Smoke Rockets	Grenade Launchers	VEESS
Obscure Objective	X	X		A	A	X	X	
Screen Breach Operations			X	X				A
Conceal Movement	A	A		X	A		A	X
Blind Snipers					A	X	X	
Hide Vehicle From ATGM	A	A			A		A	X
Screen Bridging Operations	A		A	X				
Segregate Enemy	X	A				A	A	
Support Deception	A	A	A	X				A
Screen Facilities				X				
Counter- smoke	X	A				X	A	

X = Primary System  
A = Alternate or Secondary System

## Appendix B

# Electro-Optical Systems

Smoke and obscurants influence the visual portion of the electromagnetic spectrum. They also provide protection for our forces by influencing frequency ranges we do not normally perceive with our senses.

All sensory equipment (to include the human eye, viewers, vision enhancement devices, trackers, and seekers) requires a certain amount of energy (a minimum threshold) before they can perform their functions. A sensor will also fail to function if the level of energy, in the frequency range the device is designed to work within, is too great (a maximum threshold). Smoke and obscurants provide us a means to render sensors ineffective, by decreasing or increasing the amount of energy available to the device or sensor (Figure 15).

There are three categories of obscurants: natural, by-product, and artificial. We can use natural obscurants advantageously if we correctly forecast the weather. Darkness, fog, sandstorms, and precipitation are examples of

natural obscurants. By-product obscurants on the battlefield result from combat actions. Examples include the smoke caused by the burning of buildings and equipment, dust raised by maneuvering units, and the airborne dust and particles thrown by exploding artillery and mortar fire.

We produce artificial obscurants with smoke production equipment

or munitions as described in Chapter 1 and Appendixes D and E. We use these specifically to attack enemy electro-optical (EO) systems.

Figure 16, on the next page, shows the effect obscurants have on target acquisition and guidance systems from the visible through the millimeter wavelengths of the electromagnetic spectrum.

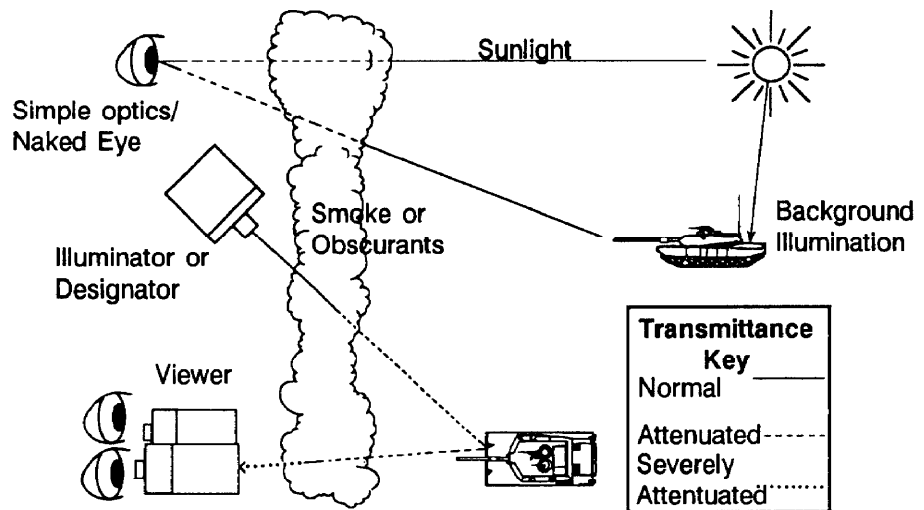

Figure 15. Obscurant effects on vision and viewers.

## Sensors and Effects

### Target Visibility

When you conceal an object by smoke, a number of factors determine the degree of obscuration. Physical properties of the object, such as size, shape, color, brightness, and reflecting properties of various parts of the surface, determine the density of the smoke required for effective obscuration.

The degree of illumination of the area, the background setting, and angle of observation have an important effect.

The overriding factor in smoke screen effectiveness is the total concentration of smoke and the path and length of the smoke cloud between the observer and the target. Thus, one observer may detect the



the right time, and in sufficient quantity.

The eye is the basic receiver for several types of EO sensors. Four sensors that rely on the eye are the naked eye itself, the telescope, the television viewer, and the image intensifier. Sensors can be active or passive depending on the mechanism they use to detect and intensify the images.

### **Operational Considerations**

The eye, the telescope, the television viewer, and the image intensifier all require illumination of the target and its background. The sun, moon, stars, or illumination rounds may provide this illumination. The eye detects reflected light and is dependent upon the contrast between the brightness of the target and its background. The telescope improves the capability of the eye by enlarging the target image.

Television viewers are used to provide viewpoints from distant, hostile, or awkward positions. Television viewers can also function as image intensifiers or to enhance contrast. Image intensifiers electronically magnify the light received, increasing it to a level the eye can see. Contrast enhancement electronically increases the brightness of the target, making it easier to see.

Passive sensors use available natural light. We use passive systems when the available light is sufficient to illuminate the target. An active viewer system consists of a viewer and an illuminator, which floods the target with light. Illuminators for different active viewing sensors include lasers, searchlights, or flares. We use active sensors when there is not enough light to illuminate the target.

### **Effects of Obscurants**

Placing obscurants between the target and the viewer will degrade the performance of these sensors. Target acquisition and identification depend on the contrast between the target and its background and the brightness of the target. Smoke and

dust will decrease this contrast and brightness by attenuating light reflected from the target. Rain, snow, fog, and haze will also degrade the performance of these systems. To use an obscurant against these sensors, place the obscurant in the line of sight between the target and the observer. Obscuration use in moonlight can also degrade the contrast of target and background. We can further degrade the contrast of a target with its background by the light from the sun that falls directly onto the obscurant and is then scattered into the line of sight. The amount of degradation depends on the position of the sun and the depth of the obscurant cloud. Degradation is greatest when both sun and target have about the same line of sight to the observer or viewer. Considerable degradation can also occur when the sun is directly behind the observer or viewer.

### **Thermal Viewers**

Passive thermal viewers use the natural thermal radiation differences between target and background to form an image – hence the name thermal viewer. Another name for a thermal viewer is forward looking infrared (FLIR). These thermal viewer systems require no external source of radiation and can successfully operate on a dark night if the targets are sufficiently warmer or cooler than the background. The thermal viewer is used in fire control systems, in some thermal homing missiles, and for surveillance purposes.

Reducing the apparent contrast between the target and its background may degrade the effectiveness of the thermal viewer. Obscurants degrade sensor performance by attenuating the target radiation signature reaching the viewer. The thermal radiation produced by the cloud may also degrade performance of the sensor. The initial burst of a munition will also produce a hot spot of thermal radiation, possibly saturating or blinding

the viewer for a few seconds. Such hot spots may also divert or decoy thermal-tracking missiles.

Most smoke attenuates thermal radiation less effectively than visual radiation, so more smoke is required to degrade thermal viewers; the relative amount depends on the agent employed. However, some smoke (for example, HC and fog oil) is not very effective against thermal viewers. High concentrations of WP and RP and black smoke are more effective against thermal viewers.

### **Command-Guided Missiles**

Most command-guided missiles are command to line of sight (CLOS) missiles, which operate in one or more spectral regions. The oldest of CLOS missiles are visually and manually controlled, requiring the operator to track both the missile and its target, while simultaneously guiding the missile to the target (for example, the Soviet Sagger). Tracking the missile can be aided by putting a beacon on the missile. This guidance scheme has been relatively easy to defeat, since either the target or the missile can be obscured, and a miss results. In addition, the flash from an exploding HE or smoke munition could serve to distract the gunner, again resulting in a miss.

The next type of missile control is semiautomatic CLOS (for example, the Dragon). In this case, the operator or gunner only tracks the target; the missile is automatically guided. This reduces the burden on the gunner and increases the accuracy. However, to cause a miss it is only necessary to obscure either the missile beacon or the target; further, the sensor tracking the missile may be blinded for a short period of time by the flash of an exploding munition. Many systems using this type of guidance use a beacon and tracking sensor that operate in the near IR. With visual target tracking this presents no difficulty. However,

with the advent of thermal imagers a situation known as spectral mismatch can occur. In this case, and under obscured condition, it may be possible to see a target with the thermal imager but not to hit the target because of obscuration of the missile beacon.

A third type of guidance is automatic CLOS. Both target and missile are tracked automatically, usually by different sensors. This type of CLOS guidance is the most sensitive to obscuration, especially with sensors operating in the shorter wavelengths.

A more recent type of guidance command for CLOS missiles is beamrider guidance. Here, a gunner tracks the target either manually or automatically while illuminating the target with a beam of light. Usually this beam is provided by a laser, and most beamriders operate in the near and far IR spectrums. Most do not use the visible portion to prevent exposing the firing position. Sensors on the rear of the missile look back at the beam projector. These sensors track the beam, and the missile guides itself to the target. Beamrider guidance suffers from the same obscuration limitations as conventional CLOS missiles with a beacon. As a rule, the lasers used in beam projectors have more power than the equivalent beacon on a CLOS missile. As a result, the laser beam is harder to obscure.

Beamrider missiles are built so that the spectral mismatch is not the weak link in terms of susceptibility to obscuration. If you track a target using the visible portion of the spectrum, guidance is performed using either the IR or millimeter wavelengths. Similarly, if target track is carried out with a thermal imager, the missile is guided using a far IR or millimeter wavelength. In effect, the target-tracking element of the beamrider system is usually the most vulnerable to obscuration.

Most CLOS missiles receive guidance commands by a wire connecting the launcher and the mis-

sile. The wire is not susceptible to obscuration; however, severing the wire (for example, by shell fragments) will result in a miss. Some CLOS missiles receive guidance commands by a radio link in the radar or millimeter portions of the spectrum. These commands are difficult to degrade using conventional obscurants. Of more importance is the effect of the electromagnetic radiation emitted during an HE detonation. This radiation may cause the missile to miss its target. As a rule, it is easier to obscure the target tracker of a beamrider system than the laser beam that guides the missile. This target tracker is usually a viewer or a thermal viewer.

Obscuring the target tracker (viewer or thermal viewer) usually causes a miss and may even prevent the gunner from launching the missile if the target cannot be seen. The flash of an exploding munition behind the missile may blind the tracking sensors on the rear of the missiles, causing the missiles to miss the target.

### **Terminal Homing Missiles**

This guidance is characterized by a missile with a seeker at the front that tracks the target and guides the missile to the target. There are two categories of terminal homing missiles: those that lock on the target before launch and those that lock on the target after launch. Missiles that lock on after launch are generally more susceptible to obscuration effects than missiles acquiring lock before launch. Terminal homing seekers operate in one or more of three modes: active, passive, or semiactive.

Most active seekers operate in the radar and millimeter wavelength regions. These seekers are not, as a rule, adversely affected by obscuration, although they may be blinded momentarily by the detonation of an HE or smoke munition. Passive seekers may operate in any spectral

region. The most common seekers operate in the IR. Passive seekers operating in the visible or IR regions may be either imaging or nonimaging.

Passive imaging seekers have essentially the same susceptibility to obscuration as any imaging sensor, although far IR imaging seekers may look on a WP cloud that is hotter than the target and track the cloud as the target. This type of seeker may also be blinded by the flash from a detonating munition and therefore miss its target.

Nonimaging IR seekers often use two spectral bands. These two bands are used to discriminate between real and false targets (such as fires or hot rocks). These seekers can be decoyed by the difference in obscuration effects upon the two spectral regions. This difference may cause the seeker to think the target is a rock (and ignore the target) or to think a fire is the target (and attack the fire). Semiactive seekers use energy reflected from the target for tracking. Usually, the target is illuminated by a laser operating in the IR. Target illumination does not have to come from the launch point or site. This type of seeker may be defeated by obscuring the beam, either before or after it is reflected from the target. If obscuration is placed closer to the laser than to the target, sufficient laser energy may be scattered by the cloud to cause the missile to track the obscurant cloud rather than the real target.

### **Radar and Millimeter Wave Sensors**

We can use radar and millimeter wave sensors to determine the position and/or velocity of the target. Since these form only poor images of the target, we do not get recognition and identification in the usual manner.

Dust and conventional smokes do not effectively degrade radar and millimeter wavelength sensors. However, other highly effective counter-



measures exist. A munition dust cloud does produce obscuration for a few seconds when the burst is in,

or very near, the line of sight. In the far term, we will use millimeter wave obscurants, projected onto

enemy positions, to degrade radar and millimeter wave sensors.

## Directed-Energy Weapons

Directed-energy weapons differ in operation and effect from all other weapons. They include lasers; high-power microwaves; particle beams; and non-nuclear, directed electromagnetic pulse (EMP). Except for lasers and high-power microwaves, directed-energy weapons are in the early stages of development.

Directed-energy weapons transmit energy at or near the speed of light in the form of subatomic particles or electromagnetic waves. This energy impacts on the target as heat or shock. Directed-energy weapons can damage soft targets and soft components of hard targets, such as lenses, electrical and electronic components, and eyes. New equipment will have built-in defenses against known directed-energy weapons. We will fit older equipment with protective devices. In the near term, we will use smoke and obscurants to reduce the impact of attack by directed-energy weapons.

### Lasers

As of 1990, no army is known to have laser devices fielded for use specifically as weapons. However, laser target designators and range finders are in the inventories of all major armies, and their numbers are increasing. Any of these laser devices can be used as a weapon. Laser weapons are effective against optical and EO systems: specifically, eyes and fire-control sights.

Laser range finders are used on the M60A2, M60A3, and M1 series tanks and our artillery units. Artillery fire support teams for airborne, ranger, and special forces units use the lightweight target designator; fire support teams for mechanized, infantry, and air-assault units use the ground-locating laser designator in either the ground-mounted or

vehicle-mounted mode; and all fire support team members use the GVS-5, binocular-type, laser range finder.

Additionally, artillery survey parties use laser devices for surveying gun positions. Scout platoons are equipped with GVS-5 laser range finders. USAF and Navy aircraft (F4, A7, F111, F105, F16, and A6 aircraft) may also carry laser target designators. Although these are not intended as weapons, accidental eye damage can occur if someone moves into a laser beam path and looks directly at the beam, or a laser beam reflects off a shiny surface into someone's eyes. A high-power laser beam striking in front of an EO device such as night vision devices or thermal imaging systems may also damage components and electrical circuits or cloud the lens.

To avoid engagement by laser weapon systems, use artillery, mortars, or direct-fire weapons to suppress known or suspected laser device locations. Smoke can temporarily defeat some laser devices. When operating within the enemy's line of sight, protect vulnerable systems by providing them cover or concealment. Cover sensor systems when not in use. If the mission requires movement, block the line of sight between friendly forces and enemy location with smoke, and/or use routes with minimal exposure time. Shoot-and-move tactics help prevent friendly positions from being pinpointed and targeted by laser devices. When searching with optical or EO devices, use as few as possible. Protect unused devices until they are needed.

### High-Power Microwaves

Electric ammunition fuzes and many missile electronic guidance systems can be damaged by microwaves. Unprotected soldiers may experience warmth, pain, headaches, fatigue, weakness, and dizziness.

Terrain masking offers some protection from microwaves. The high-power microwaves operate in the millimeter wave spectrum; thus, smoke and dust have virtually no effect and should not be used solely to degrade their performance. A munition dust cloud does produce obscuration for a few seconds when the burst is in, or very near, the line of sight. In the far term, we will use projected millimeter wave obscurants onto known or suspected enemy microwave weapon locations to block or absorb the energy at its source.

### Particle Beams

A particle beam is a directed flow of atomic or subatomic particles transmitted in a series of short pulses; it delivers large quantities of energy to targets in millionths of a second. The beam penetrates bad weather and smoke better than a laser beam and is much more destructive. The particle energy impacts in the form of heat, which melts or fractures the target. Particle beams may also create gamma and X ray when they strike metal.

Millimeter wave obscurant and type 3 IR obscurant may lessen some of the energy but will not be more than slightly effective. If a particle beam weapon is developed for ground combat, use the defensive measures taken against other direct fire weapons.

## **Electromagnetic Pulses**

An EMP is a surge of electromagnetic radiation generated by a nuclear detonation or a pulse generator. An EMP travels hundreds of miles in a fraction of a second and

can damage or destroy unshielded electrical equipment.

To protect electronic equipment against EMPs and microwaves, all cable and entry points must be shielded. The equipment should be completely encased in metal. Extra equipment or equipment not

needed at the moment should be disconnected; small, electronic items should be placed in empty ammunition cans. Millimeter wave obscurant and type 3 IR obscurant may lessen some of the energy but will not be more than slightly effective.

## Appendix C

### Means of Delivery

Smoke can be delivered to the target in numerous ways, from artillery and aircraft to grenades and gener-

ators. Your choice of delivery means will be determined by the amount of smoke needed, the dis-

tance to the target, and the availability of resources.

### Artillery Munitions

The field artillery provides effective systems for rapidly placing smoke on distant targets. They use HC, WP, and RP projectiles.

Use artillery-delivered smokes to-

- Obscure enemy observers and target acquisition and guidance systems (for example, CLOS ATGMs).
- Isolate or segregate enemy formations.

In projecting smoke onto the battlefield, the field artillery uses three types of missions: quick smoke, immediate smoke, and special smoke.

#### Quick Smoke

The objective of a quick smoke mission is to obscure the enemy's vision or to conceal maneuver elements. The quick smoke mission equates to the normal HE adjust fire mission. Obscuring the enemy is required, but the urgency of the situation does not require immediate smoke procedures. Use a quick

smoke mission to screen a small area of 150 to 600 meters for a period of 4 to 15 minutes.

#### Immediate Smoke

The objective of an immediate smoke mission is to obscure the enemy's vision immediately. Use an immediate smoke mission to obscure a point of 150 meters or less within 30 seconds for 1 1/2 to 5 minutes.

#### Special Smoke

The objective of a special smoke mission is to conceal a large area to protect or conceal maneuver forces for an extended period of time. Consider a special smoke mission when the size of the cloud makes a quick smoke mission impractical. This type of screen can vary from 400 to 2,400 meters in length.

Table 11 lists characteristics of artillery smoke munitions.

Table 11. Characteristics of artillery smoke munitions.

Type Round	Delivery System	Time to Build Effective Smoke	Average Burn Time	Range
WP	155 mm	1/2 min	1 to 1 1/2 min	18,000 m
HC		1 to 1 1/2 min	4 min	
WP	105 mm	1/2 min	1 to 1 1/2 min	11,200 m
HC		1 to 1 1/2 min	3 min	

### Mortar Munitions

Mortars can provide good initial smoke coverage because of their high rate of fire, but their small basic load limits the size and duration of the cloud they can provide. They are the most rapid and effec-

tive indirect smoke delivery means available to the maneuver commander.

Use mortar-delivered smokes to obscure enemy observers and target acquisition and guidance systems,

such as CLOS ATGMs, and to isolate or segregate enemy formations.

Table 12, on the next page, lists characteristics of mortar-delivered smoke munitions.

Table 12. Characteristics of mortar-delivered smoke munitions.

Type Round	Delivery System	Time to Build Effective Smoke	Average Burn Time	Range Min/Max
WP	4.2 in	½ minute	1 minute	920/5,650 m
WP	81 mm	½ minute	1 minute	70/4,595 m
WP	60 mm	½ minute	1 minute	75/1,629 m

## Rockets

AH/IS and AH-60 helicopters can deliver smoke munitions using the Hydra 70 rocket launcher system. The Hydra 70 fires a 2.75-inch rocket, which has a WP warhead (M156).

Use helicopter-delivered rockets to—

- Identify/mark targets for CAS aircraft and artillery.

- Obscure enemy observers and ATGM and air defense (AD) systems.

Table 13 lists characteristics of attack helicopter-delivered smoke rockets.

Table 13. Characteristics of helicopter-delivered smoke rockets.

Munition	Cloud Width	Cloud Duration
M156 WP Warhead	50 m	1 to 1½ minutes

## Aircraft-Delivered Smoke

The M52 helicopter smoke generating system is still in the US Army inventory, but in January 1982 the Army Materiel Command (AMC) type classified it as Standard B. However, it is a very effective smoke delivery method against a low-technology enemy or one with

limited air defense assets. The system contains a fog oil tank, an electrical pump to transfer fog oil to the spray apparatus, and jets on a spray ring to direct the fog oil into a hot exhaust. There, the oil is vaporized into a thick, dense, white smoke.

The UH1 helicopter is the airframe for this system. It is effective when the UH1 flies at speeds less than 90 knots and at heights not to exceed 50 feet; this makes the helicopter extremely vulnerable to air defense systems. This system has application for uses in various low-intensity conflict operations (for example, counternarcotics operations, peacetime contingency operations, and counterinsurgency operations) when the enemy has relatively few air defense systems.

Table 14. Aircraft-delivered smoke characteristics.

System	Type Aircraft	Cloud Length	Cloud Duration
M52 Smoke Device	Low Performance	40 m x 6,580 m	3 to 10 minutes

Table 14 lists the characteristics of aircraft-delivered smoke.

## Rifle Grenades

Rifle grenades can deliver smoke to point and area targets up to 350 meters away from individual soldiers. The M203 and M79 grenade launchers and the MK19 automatic grenade launcher all can fire smoke grenades. The smoke cartridges include the M713 red smoke, M715

green smoke, and M716 yellow smoke cartridges.

- Use rifle grenades to—
- Obscure snipers, enemy fighting positions, and heavy weapon emplacements.

- Provide immediate suppressive smoke to degrade enemy weapon guidance links or tracking.

- Conceal the movement of small tactical units (squad or smaller).

Table 15, on the next page, lists the characteristics of the 40-millimeter grenade launcher.

Table 15. Characteristics of 40-mm grenade launcher.

Cartridge for 40-mm Grenade Launcher	Type	Color	Burn Time
M676	Canopy	Yellow	60 to 90 seconds
M680	Canopy	White	60 to 90 seconds
M682	Canopy	Red	60 to 90 seconds
M713	Marking	Red	17 to 30 seconds
M715	Marking	Green	17 to 30 seconds
M716	Marking	Yellow	17 to 30 seconds

## Smoke Pots and Smoke Hand Grenades

### Smoke Pots

Smoke pots produce large volumes of white or grayish-white smoke for extended periods. They are the small-unit commander's primary means of producing small-area screening smoke. Pots are necessary for employing smoke on water, as the M4A2 floating HC smoke pot is the only smoke-producing system that floats.

Emplace smoke pots by hand, drop them from vehicles or helicopters, use them as a field expedient, or fasten them to the outside of armored vehicles. Ignite smoke pots

either manually (M4A2 and ABC-M5) at the emplacement site or electrically from remote positions (ABC-M5 only). The pots can be fired individually, simultaneously, or in a long-burning chain. Smoke pots are used by all services.

Table 16 lists the characteristics of US Standard A smoke pots.

### Smoke Hand Grenades

Smoke hand grenades produce either white smoke or colored smoke for short periods of time. Because they only produce small amounts of smoke, smoke hand

grenades are not effective for screening smokes for units larger than one or two squads. Emplace smoke hand grenades by hand or manually ignite them with a trip wire. This technique is effective to deceive the enemy with a diversion.

The average soldier can throw a grenade 30 to 35 meters. White smoke grenades are most often used to conceal individual vehicles; colored smoke grenades are used to mark or spot positions. All services have and use smoke grenades

Table 17, on the next page, lists current smoke hand grenades and their characteristics.

Table 16. Characteristics of Standard A smoke pots.

Type	NSN	Ignition	Burn Time (Min)	Weight (lb)		Possible Uses	Duration (Minutes)
				Filling	Total		
ABC-M5 30-1b HC	1365-00-598-52077	Ignite by manual matchhead or electrical squib	12	31	33	Small-area screens Small smoke curtains (Ground-based only)	12 to 22
M4A2 HC Floating	1365-00-598-5220	Ignite by manual fuze only Issued w/M207A1 fuze	10	27½	11	Small area screen. Small smoke curtains (ground based or over rivers, small streams, and other operations that require floating capability): may be helicopter-delivered	10 to 15

### Warning

The M4A2 smoke pot must be vented for five minutes within 24 hours prior to ignition. Vent each M4A2 pot by folding back the tape from at least two of the emission holes.

Table 17. Smoke hand grenade characteristics.

Type	Smoke Color	NSN	Weight (lb)	Possible Use	Duration (Sec)
AN-M8 HC	White	1330-00-219-8511	1.6	Marking or Small-Area Screens	105 to 150
M18	Red	1330-00-289-6852	1.2	Marking	50 to 90
	Green	1330-00-289-6851			
	Yellow	1330-00-289-6854			
	Violet	1330-00-289-6853			

## Generators

The mechanical smoke generator is a device that vaporizes smoke generator fog oil number 2 (SGF2). The vapor released condenses in the air as a white smoke. Currently, mechanical smoke generators are the only large-area smoke devices type classified Standard A. Table 18 lists generator systems and their characteristics.

Table 18. Smoke generator characteristics.

System	Prime Mover	Mobility	Obscuration Spectrum	On-Board Duration
M3A4	M998 HMMWV	Static	Visual, Near IR	1 hr
M157	M1037 HMMWV M1059 SG Carrier	Mobile	Visual, Near IR	48–96 min
XM56	M1037 HMMWV	Mobile	Multispectral	Developmental
LAMPSS	Developmental (Fully Tracked)	Mobile	Full Spectrum	Developmental

## Armored Vehicle Grenade Launchers

Three types of launchers for tanks and armored reconnaissance vehicles are designed to rapidly generate small amounts of smoke to conceal or screen individual vehicles. The vehicle commander launches the grenades as soon as he is fired upon, so the driver can take evasive action behind the smoke. The launchers fire either AN-M8 HC and M34 WP grenades (M176 launchers) or L8A1 RP and M76 IR grenades (M239 launchers).

Table 19 gives the characteristics of these self-defense grenades.

Table 19. Vehicle self-defense grenade characteristics.

Type		Total Grenades	Distance From Vehicle	Firing Arc	Time To Build Effective Smoke	Average Burn Time
Launcher	Grenade					
M176	HC, WP	8	30–40 m	90°	5 sec	90 sec
M226	HC	8	30–40 m	90°	6 sec	90 sec
M239	RP and Type III IR	12	24–30 m	110°	2 sec	1–3 min

## Vehicle Engine Exhaust System

The VEES is a vehicle-mounted smoke system that produces smoke by vaporizing fuel with the exhaust system. Vehicles that currently have the VEES include the AVLB, CEV, M88A1, M60, M1, M2, and M3 families of combat vehicles.

In a heavy brigade-size combined arms force scenario, the VEES provides a significant reduction (up to 20 percent) in the vulnerability of M1s, M2/3s, and Improved Tow vehicles. When our forces use the VEES, the lethality of BMPs from

the 1- to 2-kilometer range decreases as much as 80 percent. In summary, the lethality of enemy tanks decreases about 20 percent at close range. Self-defense smoke provides significant protection in the close battle.

# Safety

Safety with smoke and smoke delivery systems depends primarily on two things: characteristics of the

smoke and safety for the weapon or delivery systems. Tables 20 and 21 identify safety constraints and

measures for US smoke and delivery systems.

Table 20. Smoke safety constraints.

Smoke Agent	Problem/Concern	Response/Prevention
SGF2	Can cause pneumonia	Wear respiratory protection (mask) when in high concentrations of oil smoke or after 4 hours in low concentrations of oil smoke (haze)
HC	Carcinogenic	Wear respiratory protection at all times when exposed to HC smoke
WP, RP	Explosive; Can cause severe burns; Causes respiratory irritation	Do not use near friendly troops
Violet Smoke	Carcinogenic	Same as for HC

Table 21. Smoke delivery systems safety.

System	Problem	Response/Prevention
Artillery, Mortars, Rockets	Munitions are explosive. All can produce friendly casualties	Do not use near friendly troops
M239 Grenade Launcher	RP and IR grenades explosive	Safety radius of 50 meters for exposed troops in combat, 100 meters in training
M203 Grenade Launcher	Grenades explosive	Do not use near friendly troops
M18 Grenade AV-M8 HC Grenade	Burning device	Do not pick up or move when lit; wear gloves and eye protection when igniting; safety radius of 5 meters from friendly troops
M5, M5 Smoke Pots	Burning device	Same as M18 grenades. Plus: When igniting, keep head well to one side of the top of the pot and out of the way of sparks or flame. DO NOT use the pull ring or safety pin to lift a pot. Vent M4A2s. Safe distance for electrical ignition of M5 is 50 feet.
Smoke Generator	Vaporized SGF2 (See Table C-10)	Exhaust of smoke is very hot. Safety radius of 5 meters. No smoking around generator. Keep fire extinguisher within arm's reach; always add fuel from the fuel tank side; store gas can at least 15 feet from running generator. DO NOT touch engine head with bare hands.

## Appendix D

# US Smoke Organizations and Capabilities

Most chemical command and control headquarters are Reserve Component organizations. In the active Army, there are few battalion-level chemical organizations. Most corps and division-level smoke assets are

company-sized elements or smaller. Task organizing platoons from these companies provide the commander a mission-tailored mix of assets normally associated with battalion and higher levels.

This appendix describes the capabilities, limitations, and structure of chemical command and control headquarters, smoke units, and chemical unit task organizations.

## Chemical Command and Control Headquarters

The two major chemical command and control headquarters are the corps chemical brigade (HHD) (TOE 03-4721) and the corps chemical battalion (HHD) (TOE 03-476L).

### Chemical Brigade

Chemical brigades normally are assigned one to each corps. Each chemical brigade is composed of a headquarters and headquarters detachment (HHD) and two to five chemical battalions. The brigade

can provide limited administrative support, logistics, mission/operations planning, and execution supervision for the chemical battalions. The chemical brigade does not have organic supply and transportation assets for sustaining its assigned battalions.

### Chemical Battalion

Chemical battalions usually are assigned to a chemical brigade at corps, or one per TAACOM. Each chemical battalion is composed of a

headquarters and headquarters detachment and two to five chemical companies. The battalion can provide limited administrative support, logistics, mission/operations planning, and execution supervision for the chemical companies. The chemical battalion does not have a support platoon; therefore, it has no organic supply and transportation assets for sustaining its assigned companies.

## Smoke Generator Units

The major smoke generator unit tactical organizations are—

- Corps Chemical Company (SG) (Motorized) (TOE 03-067J).
- Corps Chemical Company (Smoke/Decon) (TOE 03-257J).
- Corps Chemical Company (SG) (Mechanized) (TOE 03-077J).
- Heavy Division Chemical Company (Mechanized Smoke Platoon) (TOE 03-387).
- Division Chemical Company (Airborne/Air Assault) (TOE 03-027J500/03-057L).
- Chemical Company (Smoke/Reconnaissance/Decon), Ar-

mored Cavalry Regiment (TOE 03-377L).

There are two different types of motorized systems and one mechanized smoke generator system. The M3A4 and the M157 are motorized, and the M1059 is mechanized.

Motor smoke units equipped with the M3A4 have 36 to 48 smoke generators mounted on 18 to 24 M998 series HMMWVs or M151 series 1/4-ton trucks with trailers. These smoke systems provide stationary smoke only. Depending on terrain,

the company is 100-percent mobile and is completely air-transportable.

Motor smoke units equipped with the M157 have 36 to 48 smoke generators mounted on 18 to 24 M1037 HMMWVs. This company, also, is 100-percent mobile and is completely air-transportable.

Mechanized smoke units equipped with the M1059 smoke generator carrier have six (heavy division company) or seven (mechanized smoke company) M1059s per platoon. This element is 100-percent mobile on any terrain and is completely air-transportable.



**Corps  
Chemical Company  
(SG) (Motorized)**

The motorized smoke generator company provides large-area smoke support for tactical and rear operations. The two platoons of the motorized smoke company have three squads each. There are 24 smoke generators per platoon. Each platoon (if weather, terrain, and the situation are favorable) can support up to a maneuver brigade.

**Corps  
Chemical Company  
(Smoke/Decon)**

The corps smoke/decon chemical company or dual-purpose company provides smoke and decontamination support to the light infantry division or units located in the division or corps rear area. This company has four dual-purpose platoons. Each of the four platoons can provide both smoke and decontamination support. However, the platoon can do only one mission at a time. Each platoon has two dual-purpose squads and one resupply squad. The company has 48 smoke generators — 12 per platoon.

The most difficult task of this company is the transition from decontamination to smoke support (or the reverse). This transition can be carried out at the company CP or in the BSA.

**corps  
Chemical Company  
(SG) (Mechanized)**

The mission of the chemical company (smoke generator-mechanized) is to provide smoke concealment for maneuver units and other critical areas. This company was developed because motorized companies lack the necessary armor protection and mobility to operate forward to support close operations in mid- and high-intensity conflict. It is organized into three smoke platoons. Each platoon has 14 smoke generators. (Two generators are mounted on each armored vehicle.) The seven vehicles form seven mobile point sources.

**Heavy Division  
Chemical Company  
(Mechanized  
Smoke Platoon)**

The smoke platoon of the chemical company (heavy division) gives the division a large-area smoke capability. It also provides limited site selection for decontamination squads. The platoon has six M1059 smoke generator systems. Each of the two smoke squads has three M1059s with six smoke generators per squad.

**Division  
Chemical Company  
(Airborne/Air Assault)**

This company provides smoke and decontamination support to the airborne or air assault division. This company has three dual-purpose platoons. Each of the three platoons can provide both smoke and decontamination support. However, the platoon can do only one mission at a time. Each platoon has two dual-purpose squads and one resupply squad. The company has 36 generators — 12 per platoon.

The most difficult task of this company is the transition from decontamination to smoke support (or the reverse). This transition can be carried out at the company CP or in the BSA.

**Chemical Company  
(Smoke/Recon/Decon)  
Armored Cavalry  
Regiment**

This company provides smoke and decontamination support to the armored cavalry regiment. The company has one dual-purpose platoon. Unlike other dual-purpose platoons, this platoon has seven M1059 smoke generator systems. The platoon can provide both smoke and decontamination support. However, the platoon can do only one mission at a time. The platoon has two dual-purpose squads and one resupply squad, with a total of 14 smoke generators.

## **Chemical Unit Task Organizations**

The three unique chemical unit task organizations are—

- Chemical-engineer task force.
- Chemical company team.
- Chemical battalion task force.

**Chemical-Engineer  
Task Force**

The chemical-engineer task force attaches one or more smoke or dual-purpose chemical platoons to the division engineer battalion. This provides a habitual association for logistical support for the chemical

platoons and is particularly useful when the platoon is supporting obstacle emplacement or covering force operations.

## Chemical Company Team

The chemical company team attaches one or more platoons to a chemical company for specific missions. For example, a smoke platoon from a corps motorized smoke company could be attached to a heavy division chemical com-

pany for command and control during a particular mission.

## Chemical Battalion Task Force

The chemical battalion task force attaches one or more platoons or companies to a chemical battalion for specific missions. Every smoke company in a corps chemical

brigade could be attached to a particular chemical battalion when that battalion is supporting the corps main effort. For example, if a division had to conduct a river crossing as part of the corps scheme of maneuver. The corps commander might task organize most of his smoke generator companies under one battalion for direct support of this mission.

## Capabilities

Tables 22 and 23 show smoke platoon area coverage based on the type of platoon and the number

and types of generators or point sources. The coverage is given in

kilometers; and the prime movers are listed for the generators.

Table 22. Smoke platoon coverage—mobile.

Type of Unit	SG & Prime Mover	No. of Point Sources	Average Smoke Cloud Coverage (in Meters)			
			Crosswind Width		Downwind Depth	
			Haze	Blanket	Haze	Blanket
Corps Mechanized Smoke Plt	M1059	7	600–1,500	550–1,300	100–3,600	50–1,400
Division Mechanized Smoke Plt	M1059	6	550–1,400	550–1,200	100–3,600	50–1,400
Corps Smoke/Decon Plt	M157 & M1037	6	550–1,400	550–1,200	100–3,600	50–1,400
ACR Smoke/Decon Plt	M1059	6	550–1,400	550–1,200	100–3,600	50–1,400
Corps Motor Smoke Plt	M157 & M1037	12	1,100–2,800	1,00–2,400	100–3,600	50–1,400

Table 23. Smoke platoon coverage—stationary.

Type of Unit	SG & Prime Mover	No. of Point Sources	Average Smoke Cloud Coverage (in Meters)			
			Crosswind Width		Downwind Depth	
			Haze	Blanket	Haze	Blanket
Corps Motor Smoke Plt	M3A4 & M151	24	1,000–3,400	500–1,700	600–10,000	600–10,000
	M3A4 & M998	12	500–1,700	300–900	600–10,000	600–10,000
Corps Smoke/Decon Plt	M3A4 & M988	6	300–900	100–500	600–10,000	600–10,000
Div (Abn) Smoke/Decon Plt	M3A4 & M988	6	300–900	100–500	600–10,000	600–10,000
Div (AA) Smoke/Decon Plt	M3A4 & M151	6	300–900	100–500	600–10,000	600–10,000

## Appendix E

# Smoke Support Sustainment Planning Tables

The tables in this appendix provide smoke pot spacing guidance and ammunition and fuel consumption data. Use the tables to determine ammunition or fuel

sustainment requirements for smoke missions.

Base your ammunition consumption planning on target size and smoke duration. Base fuel consumption

planning on smoke unit structure, smoke duration, and fuel delivery packaging.

## Smoke Pot Consumption

Table 24 is the spacing guide for smoke pots. When using Table 23 to determine actual spacing requirements, round up all answers

(decimals) to the next larger whole number.

Table 25, below and on the facing page, is the smoke pot consumption guide. To use this table, you must

know the length of the target area in meters and the spacing between pots in meters, plus how long the target must be smoked.

*Table 24. Smoke pot spacing guide.*

Wind Speed		Temp Gradient	Terrain	Spacing (Meters)		Meters to Target
Kmph	Knots			Haze	Blanket	
1-14	1-7	All	Open or Water	50	25	250
		Stable	Wooded	60	30	300
		Unstable or Neutral		70	35	350
15-25	8-13	All	Open or Water	40	20	200
			Wooded	50	25	250
26-32	14-17	All	Open or Water	30	15	150
			Wooded	40	20	200

*Table 25. Smoke pot consumption guide. (Part 1 of 2)*

Number of Smoke Pots Needed To Produce Smoke for a Mission												
Spacing	15m			20m			25m			30m		
	Line Length	100m	500m	1,000m	100m	500m	1,000m	100m	500m	1,000m	100m	500m
Smoke Time	100m	500m	1,000m	100m	500m	1,000m	100m	500m	1,000m	100m	500m	1,000m
15 min	12	51	102	9	13	77	8	32	62	6	27	51
30 min	24	102	204	18	78	153	15	63	123	12	48	102
1 hr	48	204	612	36	156	306	30	126	246	24	108	204
3 hr	144	612	1,224	108	468	918	90	378	738	72	324	612

Continued

Enter the table from the left-smoke time. Locate the spacing between pots at the top of the table.

Under the spacing find your target length. The cell where this column

and the smoke time row intersect contains the number of pots needed.

## Fuel Consumption Tables

Use Tables 26 and 27 to determine fog oil and MOGAS consumption for smoke generators. These tables are based on normal con-

sumptions of a smoke generator platoon running all generators simultaneously. When a crew operates a

single M3A4 or M157 smoke generator, multiply the planning figure by 0.5.

Table 26. Fog oil consumption in gallons and [drums].

Platoon Type	1 hr	2 hr	4 hr	6 hr	24 hr	48 hr
<b>Motor Smoke (24 Generators)</b>	1,200 [22]	2,400 [44]	4,800 [88]	7,200 [131]	28,800 [524]	57,600 [1,048]
<b>Mechanized (7 M1059 Systems)</b>	700 [13]	1,400 [26]	2,800 [51]	4,200 [77]	16,800 [306]	33,600 [611]
<b>Dual Purpose (12 Generators)</b>	600 [11]	1,200 [22]	2,400 [44]	4,800 [88]	7,200 [131]	28,800 [524]
<b>Heavy Division Smoke Plt (6 M1059 Systems)</b>	600 [11]	1,200 [22]	2,400 [44]	4,800 [88]	7,200 [131]	28,800 [524]

Numbers in brackets = Drums

One drum = 55 gallons

Table 27. MOGAS consumption in gallons and .

Platoon Type	1 hr	2 hr	4 hr	6 hr	24 hr	48 hr
<b>Motor Smoke (24 Smoke Generators)</b>	72 [15]	144 [29]	216 [44]	864 [173]	1,728 [346]	3,456 [692]
<b>Mechanized Smoke (14 Smoke Generators)</b>	42 [9]	84 [17]	168 [34]	252 [51]	1,008 [202]	2,016 [404]
<b>Dual Purpose (12 Smoke Generators)</b>	36 [8]	72 [15]	144 [29]	216 [44]	864 [173]	1,728 [346]
<b>Heavy Division Smoke Plt (12 Smoke Generators)</b>	36 [8]	72 [15]	144 [29]	216 [44]	864 [173]	1,728 [346]

Numbers in brackets = Cans

1 Can = 4.5 gallons in a 5-gallon can

Table 25 continued. (Part 2 of 2)

Number of Smoke Pots Needed To Produce Smoke for a Mission												
Spacing Line Length	40m			50m			60m			70m		
	100m	500m	1,000m	100m	500m	1,000m	100m	500m	1,000m	100m	500m	1,000m
Smoke Time 15 min	6	21	39	5	17	32	5	14	27	3	12	23
30 min	12	42	78	9	33	63	9	27	48	6	24	45
1 hr	24	84	156	18	66	126	18	54	108	12	48	90
3 hr	72	252	468	54	198	373	54	162	324	36	144	270

# Ammunition Consumption Tables

Use Tables 28 through 31, below, to determine consumption rates for artillery, and mortar munitions.

Start with the wind speed, rate of fire, (or weapon and target size) and duration of smoke requested,

and use the table to discover the number of rounds required for the mission.

*Table 28. Quick smoke consumption data—155-mm smoke shell.*

Fire for Effect—Rounds Per Tube													
Wind Speed in Knots	Rate of Fire	Duration Requested by Forward Observer (in Minutes)											
		4	5	6	7	8	9	10	11	12	13	14	15
5	1 rd/min	2	2	3	3	4	4	5	5	6	6	7	7
10	1 rd/30 sec	2	3	4	5	6	7	8	9	10	11	12	13
15	1 rd/20 sec	3	4	6	7	9	10	12	13	15	16	18	19

*Table 29. Quick smoke consumption data—155-mm WP shell.*

Fire for Effect—Rounds Per Tube															
Wind Speed in Knots	Rate of Fire	Duration Requested by Forward Observer (in Minutes)													
		2	3	4	5	6	7	8	9	10	11	12	13	14	15
14515	1 rd/min	3	4	5	6	7	8	9	10	11	12	13	14	15	16
10	1 rd/30 sec	4	6	8	10	12	14	16	18	20	22	24	26	28	30
15	1 rd/20 sec	6	9	12	15	18	21	24	27	30	33	36	39	42	45

*Table 30. Smoke ammunition consumption—artillery battery.*

Weapon (Target Size)	Duration of Mission	Total Rounds
155-mm HC (2,800 m x 50 m)	5 min	16
	10 min	40
	15 min	56
155-mm WP (1,200 m x 50 m)	2 min	24
	5 min	48
	15 min	128
105-mm WP (450 m x 35 m)	2 min	18
	5 min	36
	15 min	96

*Table 31. Smoke ammunition consumption—mortar platoon.*

Weapon (Target Size)	Duration of Mission	Total Rounds
107-mm WP (600 m x 40 m)	2 min	12
	5 min	27
	15 min	72
81-mm WP (300 m x 35 m)	2 min	12
	5 min	27
	15 min	72
60-mm WP (225 m x 35 m)	2 min	12
	5 min	27
	15 min	72

All figures assume 9 kmph crosswind.

All figures assume 9 kmph crosswind.

## Weather and Terrain

Environmental factors and terrain affect smoke cloud behavior. Steer-

ing winds, temperature gradients and the type of terrain are impor-

tant for accurately predicting smoke cloud travel.

### Weather

Meteorological conditions that have the most effect on smoke screening and munitions expenditures (including the deployment of smoke generators) include wind, temperature gradients, humidity, precipitation, and cloud cover.

#### Wind

The weather condition with the greatest impact on smoke operations is wind. Both wind direction and wind speed play a significant role in almost everything that deals with smoke operations. These factors are important in estimating equipment, munitions, and fog oil requirements for a smoke operation.

Wind direction determines where smoke must be released and where it will travel. Basically, there are four different types of wind directions that affect smoke operations: head winds, tail winds, flanking winds, and quartering winds. Favorable wind directions in relation to the smoke objective are the tail, quartering, and flanking winds (see Figure 17).

**Head winds** are those blowing from the smoke objective directly toward the smoke source and are unfavorable for smoke generator operations.

**Tail winds**, the most favorable for smoke operations, blow toward the smoke objective from behind the smoke source.

**Flanking winds** blow directly across the smoke objective and the smoke source and are generally favorable for smoke operations.

**Quartering winds** blow between the other winds toward the smoke objective.

It is important to make the distinction between those surface wind directions just discussed and steering winds. Steering winds occur between 6 meters and 200 meters above the earth's sur-

face. They are the winds that actually carry the smoke and determine the direction of smoke travel.

Wind speed has as much influence on smoke behavior as wind direction has. Low wind speed or calm conditions allow smoke to remain in the target area for a longer period of time. In addition, some types of smoke behave differently at different wind speeds. For example, WP tends to pillar if winds are less than 9 knots (17 kilometers per hour). HC smoke rises when the wind speed is less than 4 knots (7 kilometers per hour), and it is torn apart by wind speeds over 13 knots (24 kilometers per hour). Smoke from mechanical smoke generators may be effective in higher wind speeds because of the great volume produced.

#### Temperature Gradients

Temperature, by itself, has no direct relationship with making effective smoke. It does, however, have an indirect relationship, which is a result of temperature gradients. Temperature gradients are determined by comparing the air temperature at .5 meter above the ground with the air temperature at 4 meters. Three types of temperature gradients influence smoke: unstable (lapse), neutral, and stable (inversion) (Figure 18, next page).

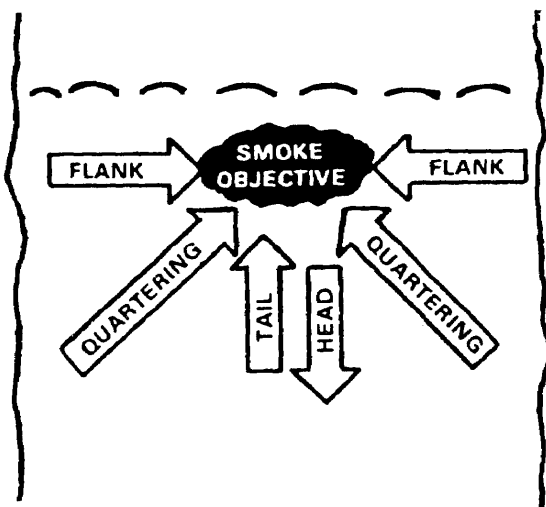

Figure 17. Classification of wind directions.

**Unstable.** An unstable (lapse) condition exists when air temperature decreases with an increase in altitude. This condition is characterized by vertical air currents and turbulence. Thus, smoke tends to break up and become diffused. Lapse conditions are best for producing smoke curtains.

**Neutral.** A neutral condition exists when air temperature shows very little or no change with an increase in altitude. Neutral conditions also exist when the wind speed is greater than 9 kilometers per hour. Under this condition, vertical air currents are very limited. Neutral conditions are best for smoke hazes and smoke blankets; however, this is not the most favorable temperature gradient for smoke.

**Stable.** A stable (inversion) condition exists when the air temperature increases with an increase in altitude. This condition greatly limits vertical air currents. A smoke cloud produced during inversion conditions lies low to the ground and

may reduce visibility at ground level. Inversion conditions are excellent for smoke hazes and smoke blankets but only if there is enough wind to carry the smoke over the target area.

### Humidity

Practically all smoke particles absorb moisture from the air. Moisture increases particle size and density and makes the smoke more effective. Most smoke munitions produce a denser (thicker) smoke when the humidity is high than when it is low; therefore, high humidity is generally favorable for smoke employment (Table 32).

### Precipitation

Since light rains decrease visibility, less smoke gives concealment during these rains. Heavy rains and

snow reduce visibility; therefore, smoke is rarely needed for concealment during those conditions. When used during periods of precipitation, smoke tends to remain close to the ground and spread out over a large area.

### Cloud Cover

The amount of clouds in the sky gives an indication of how smoke will act on the battlefield. The general rule is when the sky is covered with clouds, the atmosphere is relatively stable, and the conditions are generally favorable for making smoke.

Table 33, on the next page, provides a summary of favorable and unfavorable conditions for smoke production.

Table 32. HC and WP smoke yields in various humidities.

Relative Humidity	HC	WP
%	Effectiveness (Percentage)	Effectiveness (Percentage)
0	100	100
10	146	353
20	152	372
30	159	391
40	173	411
50	189	434
60	211	465
70	240	510
80	325	588
90	572	785



Time of Day and Weather Conditions	Temperature Gradient	Smoke Behavior (Wind Direction→)
Night—until 1 hr after sunrise. Wind speed is less than 9 kmph (5 knots). Cloud cover less than 30%.	Stable (Inversion) (Ideal)	
Day—most often between 1 to 2 hr before and after sunrise. Wind speed is 9 kmph (5 knots) or more. Cloud cover is 30% or more.	Neutral (Favorable)	
Day—beginning 2 hr after sunrise. Wind speed is less than 9 kmph (5 knots). Cloud cover is less than 30%.	Unstable (Lapse) (Marginal)	

Figure 18. Temperature gradient effects on smoke.

### Terrain Effects

Since smoke is carried by the wind, it usually follows the contours of the earth's surface. Therefore, the type of terrain over which the smoke travels has a tremendous impact on how effective the smoke

coverage will be in a specified area. Smoke will act differently over the different types of terrain.

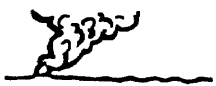
#### Flat, Unbroken Terrain and Over Water

On flat, unbroken terrain, and over water, the individual smoke streamers take longer to spread out

and mix with other streamers. Therefore, the uniform phase will usually develop a greater distance downwind.

### Obstructions

Obstructions, such as trees and small buildings, tend to break up smoke streamers. These streamers re-form, cover a much larger area, and eventually create a more uniform screen. This uniform screen develops much quicker and closer to the smoke source than if the terrain were open. A wooded area, which contains an abundance of obstructions, is the most favorable type of terrain for smoke generator operations.

### Large Hill Masses and Mountains

Steep hills and mountains tend to split winds. The winds eddy around the hills and mountains as well as over them. Large hill masses and rugged terrain cause strong cross currents. These currents disperse smoke excessively and create holes and unevenness in the smoke screen. In addition, thermally induced slope winds occur throughout the day and night. These conditions make it extremely difficult to establish and maintain a smoke screen. Wind currents, eddies, and turbulence in mountainous terrain must be continuously studied and observed.

### Slopes and Valleys

In areas where there are valleys and other types of slopes, the climatic conditions are usually different at different times of the day. These areas are characterized by thermally induced slope winds that occur throughout the day and night. During the daytime, the heating effect causes these winds to blow up the slope, and they are referred to as up-slope winds. At night, the cooling effect causes the winds to blow down the slopes, and they are called down-slope winds. This is a very general rule; however, it is one which needs to be kept in mind when planning smoke operations.

Table 33. Evaluating conditions for smoke employment.

Factor	Unfavorable	Moderately Favorable	Favorable
Wind	More Than 10 knots	Less Than 10 Knots	5 to 10 Knots
Atmospheric Stability Category	Unstable (Lapse) (Favorable for Smoke Curtain)	Neutral	Stable (Inversion) (Unfavorable for Smoke Curtain)
Humidity	Low	Moderate	High
Precipitation	None	Light Rain	Mist/Fog
Cloud Cover	None	Scattered	Overcast, Low Ceiling
Terrain	Even	Gently Rolling	Complex Topography
Vegetation	Sparse or None (Desert)	Medium Dense	Heavily Wooded or Jungle
Time of Day	Late Morning thru Late Afternoon	Midmorning	1 Hour Before EENT to 4 Hours After BMNT

BMNT—beginning morning nautical twilight

EENT—ending evening nautical twilight



## Appendix G

# Obscurants and How They Work

Obscurants are particles suspended in the air that block or attenuate a portion (or portions) of the electromagnetic spectrum. The six types of obscurants are natural

obscurants (such as fog); by-product obscurants (such as dust); visual smoke (such as WP); and bispectral multispectral and special obscurants. This appendix describes

the general characteristics of obscurants, how they work, and what obscurants the United States has in its inventory.

## Characteristics

Obscuration occurs when there is a decreased level of energy available for the function of seekers, trackers, vision enhancement devices, or the human eye. Battlefield visibility can be practically defined as the distance at which a potential target can be seen and identified against any background. Reduction of visibility on a battlefield by any cause reduces the amount of smoke needed to obscure a target or objective.

Obscuration generally is not associated with combat power because it is not a lethal tool on the battlefield. However, the deliberate use of smoke and the inadvertent or planned use of dust and/or adverse weather conditions on the battlefield have always been of value to units in the field.

In general, smokes are composed of many small particles suspended in the air. These particles scatter and absorb (attenuate) different spectra of electromagnetic radiation. This absorption reduces transmittance of that radiation through the smoke. When the density (concentration) of smoke material between the observer or EO device and an object exceeds a certain minimum threshold value (Cl), the object is considered effectively obscured.

Smoke, placed between a target and viewer, degrades the effectiveness of that viewer by interfering with the reflected electromagnetic radiations. The amount of smoke required to defeat that viewer is highly dependent upon meteorological conditions, terrain relief, available natural light, visibility, and the absorption effect of natural particles in the atmosphere. Other factors include smoke from battlefield fires and dust raised from maneuvering vehicles and weapon fire.

The ability to detect and identify a target concealed by such a smoke cloud is a function of target-to-background contrast. Smoke clouds reduce target-to-background contrast, making the target more difficult to detect.

The effectiveness of obscuration depends primarily upon characteristics such as the number, size, and color of the smoke particles. In the visible range, dark or black smoke absorbs a large proportion of the electromagnetic waves striking individual smoke particles. During bright sunlight you need a higher concentration of black smoke to effectively obscure a target because black smoke particles are nonscattering. At night or in limited visibility, considerably less black smoke is needed.

Grayish or white smoke obscures in the visible range by reflecting or scattering light, producing a glare. During bright sunlight you need a lower concentration than with black smoke to effectively obscure a target. At night or in limited visibility, considerably more than black smoke is needed.

Years of experience with white smoke technology have shown it to be superior to black smoke for most applications. Available white smoke producers include WP and RP compounds, HC, and fog oil (SGF2). WP, RP, and HC are hydroscopic (that is, they absorb water from the atmosphere). This increases particle diameters and makes them more efficient in scattering light. Fog oils are nonhydroscopic and depend upon vaporization techniques to produce extremely small diameter droplets that absorb and scatter light.

Smoke produced by a smoke generator unit or from a series of smoke pots has four distinct phases: streamer, build-up, uniform, and terminal (see Figure 19, on the next page).

**Streamer phase** is the smoke cloud formed by a single smoke device before it begins to blend with the smoke from other sources.

**Build-up phase** is the stage of smoke cloud production when individual streamers begin to merge.

**Uniform phase** is a uniform smoke cloud that occurs after individual smoke streamers have merged. This is the phase commanders want over the target area.

**Terminal phase** is the stage of a smoke cloud in which the smoke has dispersed and concealment is no longer effective.

The diffusion of smoke particles into the atmosphere just above the earth's surface obeys physical laws. Wind speed, turbulence, atmospheric stability, and terrain all govern diffusion of smoke. Smoke

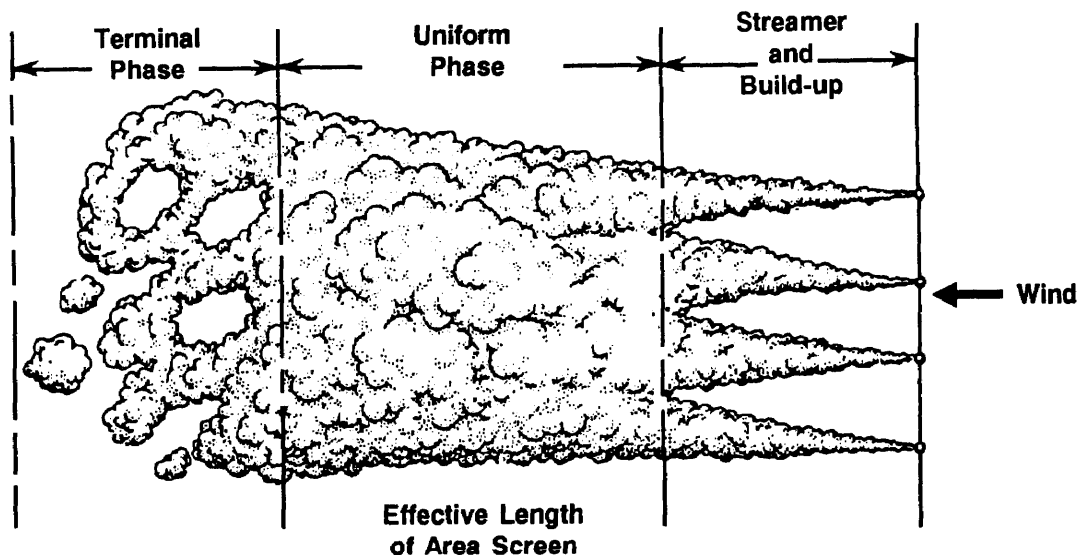

Figure 19. Phases of large-area smoke cloud.

diffusion on the battlefield originates from four basic smoke source configurations:

- Continuous point sources (such as smoke release from a smoke generator or smoke pot).
- Instantaneous point sources (such as bursting of a WP projectile).

- Continuous line sources (such as a series of smoke generators set up crosswind).
- Area sources (such as munitions that scatter smoke-generating submunitions like the armored vehicle smoke grenade launchers).

## Natural Obscurants

Natural obscurants are produced by nature and are therefore no drain on our assets. However, they are uncontrollable and may aid the enemy as much as friendly forces. We can use natural obscurants to our advantage if we accurately predict the weather and if there is a firm understanding of the impact of that weather on the battlefield. Natural obscurants will create large recognition and identification problems. Examples of natural obscurants are darkness, fog, sandstorms, and precipitation.

### Darkness

Darkness is the most common form of obscuration found on the battlefield. Darkness will degrade visual observation and target-acquisition devices that are not equipped with active infrared, image intensification, or thermal imaging. Systems equipped with these devices

can operate at near-normal efficiency during periods of reduced visibility or darkness.

### Fog

Fog can be an effective form of obscuration for use on the battlefield. Fog has the capability of providing a good obscurant on the battlefield because it will attenuate visual and near infrared signals in the same manner as visual smoke. Ice fog can also be a very effective obscurant because it degrades systems that operate by the use of a longer wavelength such as thermal imagers. Fog also degrades laser range finders and target designators.

### Sandstorms

Sandstorms are encountered in arid and semiarid regions and can have a dramatic effect on military operations. These storms will usual-

ly effectively obscure all observation and target acquisition devices with the possible exception of ground surveillance radars and other related devices operating in the microwave region of the electromagnetic spectrum.

### Precipitation

Precipitation can definitely obscure battlefield viewers depending on the concentration. Rain, mist, sleet, or snow will degrade battlefield visibility greatly. When these elements are present in heavy concentration, there is no need to produce smoke. These elements can reduce visibility by themselves. The use of image intensifiers, active infrared systems, thermal imagers, laser range finders, and ground surveillance radars can be degraded and possibly defeated when the concentration of precipitation is heavy.

## By-Product Obscurants

By-product obscurants that produce concealment are a result of other activities associated with battlefield operations. They are often inadvertent; however, when understood, they may be planned and used to the advantage of friendly forces. Examples of by-product obscurants are smoke from burning vehicles and buildings and dust caused by vehicular movement and artillery/mortar fire.

### By-Product Smoke

Smoke produced by fire on the battlefield will obscure viewers. This fire can be man-made or naturally produced by elements such as lightning. Other methods of generating fires that may result from a man-made device are fires produced by mortar or artillery rounds. Whether naturally produced or man-made, this obscurant will decrease visibility on the battlefield.

### Dust

Battlefield dust is like the proverbial two-edged sword: its presence and use can cut both ways. For example: dust can be used for —

- Concealing details of military forces and movement. Dust is often an indicator of movement of troops and equipment. If the amount of dust generated is large (perhaps deliberately so), details of troop movement can be obscured. If no dust is desired, a simple expedient is to keep the road wet, which can be done if sufficient equipment and ample water are available.

- Blinding enemy observation points to deprive him of the opportunity to adjust fire. Artillery volleys or naval salvos can be used to temporarily obscure a narrow field of view for a short period of time. HE dust clouds are generally only effective as obscurants for several seconds but may be effective up to a minute or more.

- Degrading performance of precision-guided munitions and EO sensors. HE dust can be used to interfere with the target acquisition sequence or to break "lock-on" of an acquired target.

Dust, depending on how it is produced, can obscure different portions of the electromagnetic spectrum, in either the visible, infrared millimeter wave, or radar portions. Dust is often produced inadvertently by bombing, gunfire, and vehicular movement. However, we can plan and use dust to the advantage of friendly forces. Dust degrades the performance of sensors and precision-guided munitions.

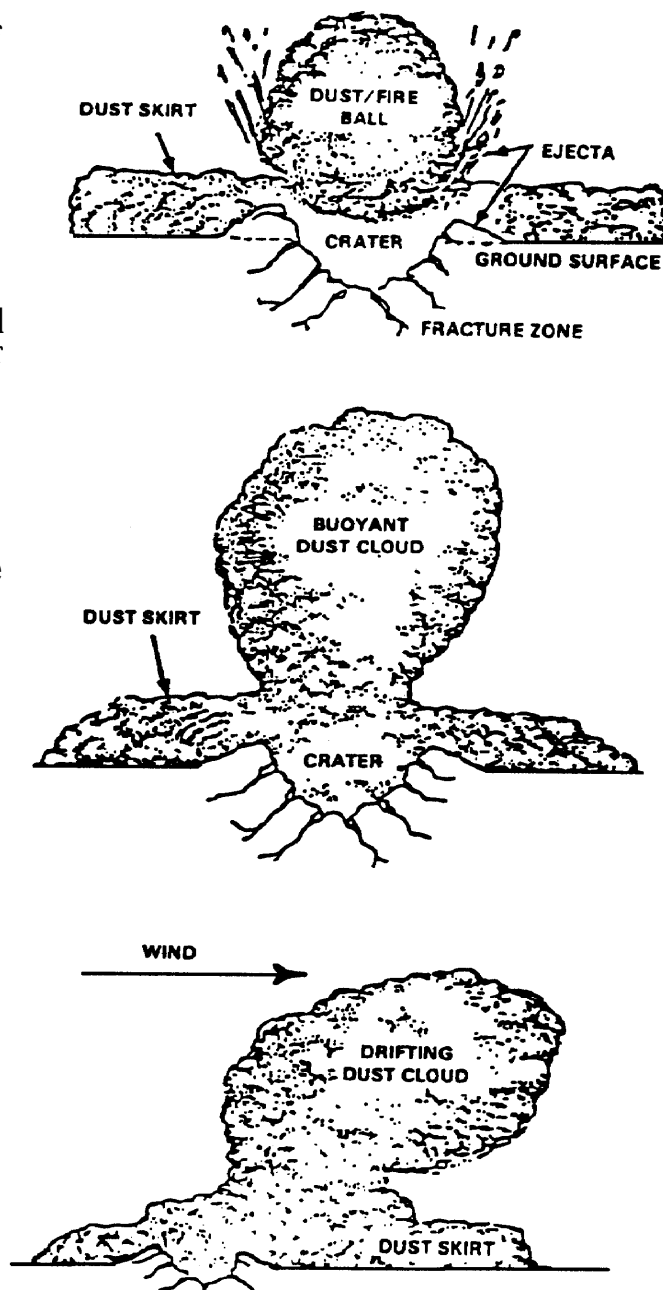

Figure 20. Phases of munition-produced dust cloud.

## Munition-Produced Dust

When HE munitions are used, dust will be produced. The amount produced depends on the size of the munition, its point of detonation (above or below the surface), and the state of the soil. The initial explosion throws up a variety of crater materials. From small clumps down to individual soil particles, obscuration will occur at all frequency bands of the electromagnetic spectrum (assuming the explosion is on or near the line of sight). Obscuration times are generally 3 to 10 seconds in the millimeter wave portion of the spectrum; this is the amount of time required for the small clumps and large particles to fall back to the ground. The remaining airborne dust that forms the drifting dust cloud continues to provide obscuration in the visible

and infrared portions of the spectrum.

As a rule of thumb for drier soils, dust generally has less effect on IR sensors than on visual sensors such as the eye. For moist or very sandy soils, the two sensors are often affected equally, and under some conditions the IR sensors are obscured more than the visual sensors. In general, infrared sensors will usually offer some advantage over visible-radiation sensors when looking through dust.

Figure 20, at left, shows the phases of a munition dust cloud. The initial phase lasts only a few seconds and quickly blends into the rise phase that lasts about 10 seconds or less. The degree and time of obscuration depend on the dust cloud drift and dissipation phase of the dust cloud with respect to the line of sight and the

weather conditions. Dust clouds created by HE have three successive phases: impact, rise, and drift and dissipation.

- Impact phase. Upon munition impact, two parts of a dust cloud are created instantaneously. One part is the hot dust or fire ball, which has an initial size of 4 to 6 meters and is close to the surface. The dust or fire ball is initially several hundred degrees hotter than its surroundings. Most of the dirt and dust are contained in this initial dust or fireball. The second part is the dust skirt, which has a greater horizontal extent of 6 to 10 meters high, and has nearly the same temperature as its surroundings.

- Rise phase. The initial dust or fireball begins to rise and expand, cooling as it rises. The dust cloud top may reach heights of 10 to 30 meters in less than 10 seconds. The dust skirt does not rise but will continue to diffuse outward.

- Drift and dissipation phase. The entire dust cloud, both the buoyant part and the nonbuoyant dust skirt, begin to drift. Wind causes the upper portion to move out ahead while the lower dust skirt lags behind. As the dust cloud drifts, it diffuses, becoming thinner and gradually dissipating.

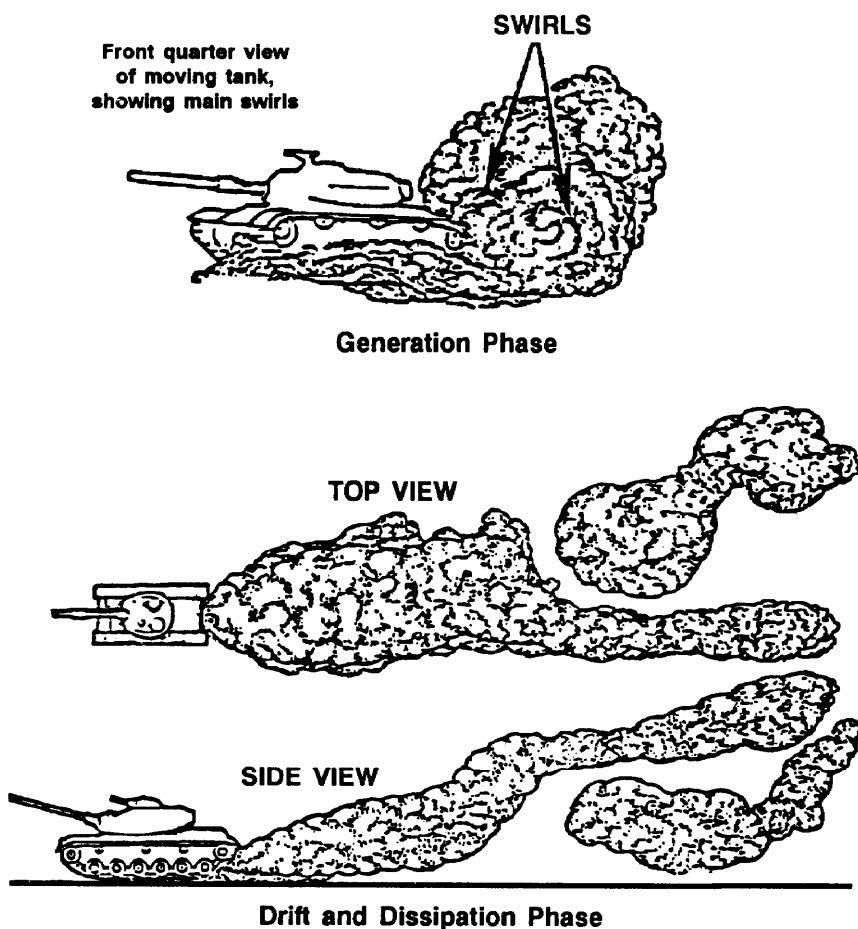

Figure 21. Vehicular dust cloud generation phase and drift and dissipation phase

## Vehicular Dust

The amount of dust produced by vehicular traffic depends on the weight of the vehicle, the number of wheels (or tread area), the speed of the vehicle, and the state of the soil. Because vehicles kick up the smaller particles present on the soil surface, vehicular dust does not effectively attenuate the radar or the millimeter wave portions of the spectrum. However, vehicular dust clouds can provide effective obscuration in the visible and infrared portions of the spectrum. Vehicular dust can be divided into two phases: generation and drift and dissipation (Figure 21).

- Generation phase. In this phase, the dust is thrown up or lifted off the surface by the vehicle's wheels

or treads and is swept up in the turbulent air under and behind the vehicle. The total amount of dust produced increases with the speed of the vehicle.

- Drift and dissipation phase. After the dust has been swept up behind the vehicle, it begins to drift and diffuse with the wind. As before, the degree and duration of obscuration

depend on the position of the dust trail with respect to a line of sight and the weather conditions.

## Artificial Obscurants

We cannot control the behavior of natural and by-product obscurants with the degree of certainty required to defeat enemy RSTA efforts. While natural and by-product obscurants block or attenuate portions of the electromagnetic spectrum, we must produce obscurants artificially to attack enemy electro-optical systems. We classify US obscurants as visual, bispectral, multispectral, and special.

While 98 percent of all current battlefield viewers operate in the visual portion of the spectrum, future systems will acquire and engage, using IR and millimeter wave technologies. This will require integration of each class of US obscurant to attack and defeat these systems. The following portions of this appendix describe the militarily significant, artificially produced obscurants.

### Visual Smoke

Many years of experience with smoke technology has shown white smoke to be superior to black smoke for most applications. Currently we have no black smoke production agents, although the US Navy does have black smoke production capability. The three principle agents for producing white smoke are oils (SGF2 and diesel), HC, and phosphorous.

### Oil Smoke

We make oil smoke by vaporizing fuel oils in mechanical smoke generators or engine exhausts. The generator or engine exhaust vaporizes either SGF2 or diesel fuel and for-

ces into the air where it condenses into a dense white smoke. This smoke can produce effective obscuration of the visual through near-infrared portions of the electromagnetic spectrum.

### Hexachloroethane Smoke

HC is a pyrotechnic composition of hexachloroethane, zinc oxide, and aluminum powder. A pyrotechnic starter mixture usually ignites the burning reaction. The smoke produced is zinc chloride during burning. This zinc chloride reacts with the moisture in the air to form a zinc chloride solution in tiny droplets: smoke. When first produced, HC smoke is very hot but cools rapidly and has little tendency thereafter to rise. HC munitions generally have definite burn times, which are useful for planning purposes.

### Phosphorous Smoke

#### Caution

HC is carcinogenic. Soldiers must wear respiratory protection (for example, a protective mask) while in HC smoke.

Phosphorus is a flammable solid that burns to form solid particles of phosphorous pentoxide in the air: smoke. The phosphorous pentoxide then reacts with moisture in the air to form phosphoric acid. We use phosphorous smokes in instantaneous-burst munitions (for example, artillery and rifle grenades), with the showers of burning phos-

phorous particles being highly incendiary. This makes phosphorous smoke excellent for harassing enemy personnel and starting fires, as well as its having excellent smoke properties.

Phosphorous smoke burns so hot

#### Caution

Phosphorous smoke produces phosphoric acid. Soldiers must wear respiratory protection, such as protective masks, if exposed to phosphorous smoke.

that it tends to form a pillar of smoke, which rises rapidly. While this pillaring reduces the efficiency of phosphorous smoke, the by-product of the heat is that it obscures from the visual through the far-infrared portions of the electromagnetic spectrum. The three phosphorous smokes are WP, PWP, and RP.

WP is a spontaneously flammable natural element. It ignites on contact with air and is relatively unstable in storage. WP burns at 5,000 degrees Fahrenheit, making it the most effective smoke agent to defeat thermal imagery systems.

PWP is a formulation of white phosphorus and some other agents (for example, butyl rubber) to stabilize the smoke agent fill and slow the burning. This slowed burning tends to produce a more coherent smoke cloud with less pillaring.

RP is not spontaneously flammable, requiring ignition to burn and make smoke. RP burns at a lower temperature - 4,000 degrees Fahrenheit - which produces a

more coherent smoke cloud with less pillaring. It is less incendiary than either WP or PWP, making it safer for use in smaller cartridges (for example, 40-millimeter grenades). Some munitions such as the M825 155-millimeter howitzer cartridge use felt wedges saturated with RP to produce an even distribution of smoke agent around the point of burst.

### **Bispectral Obscurants**

Bispectral obscurants defeat or degrade two portions of the electromagnetic spectrum simultaneously. As previously stated, phosphorous smokes defeat both

the visual and infrared portions of the spectrum. Other bispectral capabilities include type III IR obscurant, which is a micropulverized metal compound. Currently we use this bispectral obscurant in self-defense systems only (for example, the M76 smoke grenade for armored vehicle grenade launchers). In the near term we will have and use a large-area bispectral obscurant capability.

### **Multispectral Obscurants**

As implied by the name, multispectral obscurants will defeat or

degrade multiple portions of the electromagnetic spectrum. Challenges associated with this technology include preventing the inadvertent suppression of friendly force EO systems. In the mid-term we will have and use multispectral obscurants.

### **Special Obscurants**

Special obscurants will defeat specific portions of the electromagnetic spectrum.

Appendix H

**PROBABILITY OF DETECTION**

**PROBABILITY OF DETECTION**

AIR STABILITY	WIND SPEED (MPH)	SOURCE STRENGTH (6 GENERATORS)	DOWNWIND DISTANCE (KM)	PROBABILITY OF DETECTION
UNSTABLE	5	5 lbs/min	1	55%
			3	75%
			5	95%
	5	10 lbs/min	1	35%
			3	60%
			5	80%
	10	5 lbs/min	1	85%
			3	100%
			5	100%
	10	10 lbs/min	1	55%
			3	85%
			5	100%

**PROBABILITY OF DETECTION**

AIR STABILITY	WIND SPEED (MPH)	SOURCE STRENGTH (6 GENERATORS)	DOWNWIND DISTANCE (KM)	PROBABILITY OF DETECTION
NEUTRAL	5	5 lbs/min	1	25%
			3	50%
			5	80%
	5	10 lbs/min	1	15%
			3	40%
			5	55%
	10	5 lbs/min	1	40%
			3	65%
			5	80%
	10	10 lbs/min	1	10%
			3	25%
			5	40%



**PROBABILITY OF DETECTION**

AIR STABILITY	WIND SPEED (MPH)	SOURCE STRENGTH (6 GENERATORS)	DOWNWIND DISTANCE (KM)	PROBABILITY OF DETECTION
<b>STABLE</b>	5	5 lbs/min	1	0%
			3	5%
			5	10%
	5	10 lbs/min	1	0%
			3	0%
			5	5%
	10	5 lbs/min	1	5%
			3	15%
			5	25%
	10	10 lbs/min	1	0%
			3	5%
			5	5%



# Glossary

- AA - assembly area.
- AAR - after action report.
- abn - airborne
- ACR - armored cavalry regiment.
- ACRV - artillery command and reconnaissance vehicle.
- aerosol - fine particles of solids or liquid suspended in air.
- AD - air defense.
- AG - advanced guard.
- AICV - armored infantry combat vehicle.
- AirLand battle imperatives - key operating requirements for success on the battlefield to ensure unity of effort; anticipate events on the battlefield; concentrate combat power against enemy vulnerabilities; designate, sustain, and shift the main effort; press the effort; move fast, strike hard, and finish rapidly; use terrain, weather, deception, and OPSEC; conserve strength for decisive action; combine arms and sister services to complement and reinforce; understand the effects of battle on soldiers, units, and leaders.
- AMC - Army Materiel Command.
- APC - armored personnel carrier.
- arty - artillery.
- ASG - area support group.
- ASP - ammunition supply point.
- ATGM - antitank guided missile.
- attenuate - reduce the effectiveness, amount, or force of.
- bispectral obscurant - an obscurant that blocks or attenuates two portions of the electromagnetic spectrum (such as visual and infrared).
- blanket - See smoke blanket.
- BMNT - beginning morning nautical twilight.
- bn - battalion.
- BSA - brigade support area.
- build-up phase - the second stage of smoke cloud production; occurs when the individual smoke streamers start to merge.
- CAS - close air support.
- CCA - Combat Command A.
- CEOI - Communications-Electronics Operation Instructions.
- CEV - combat engineer vehicle.
- CFL - coordinated fire line.
- CFV - cavalry fighting vehicle.
- CLOS - command to line of sight.
- CMO - civil military operations.
- COSCOM - corps support command.
- CP - command post.
- CRP - combat reconnaissance patrol.
- CRSTA - counterreconnaissance, surveillance, and target acquisition.
- CSS - combat service support.
- curtain - See smoke curtain.
- DAG - division artillery group.
- decon - decontamination.
- deliberate smoke - characterized by integrated planning; may be used for extended periods for stationary or mobile missions.
- det - detachment.
- DEW - directed-energy weapon (such as high-energy microwaves, lasers).
- DISCOM - division support command.
- DPICM - dual-purpose improved conventional munition.
- DS - direct support.
- DSA - division support area.
- EA - engagement area.
- EENT - ending evening nautical twilight.
- eff - effective.
- electro-optical system - a device that detects targets by converting the electromagnetic radiation (visible, infrared, microwave) given off by the target into electric current; this current is amplified, then used to power a viewer or targeting system; this device can detect targets not visible to the naked eye.
- EMP - electromagnetic pulse.
- EO - electro-optical.
- EW - early warning.
- FA - field artillery.
- far infrared - electromagnetic energy with wavelengths of 8 to 14 micrometers.
- FASCAM - family of scatterable mines.
- FDC - fire direction center.
- FEBA - forward edge of the battle area.
- FFL - free fire line.
- flank wind - a wind that blows directly across a line between the

smoke objective and the smoke source.

FLIR - forward looking infrared.

FLOT - forward line of own troops.

fog oil - petroleum compounds of selected molecular weight and composition to facilitate formation of smoke by atomization or combustion; the resultant smoke is white.

FScell - fire support cell.

FSCOORD - fire support coordinator.

FSE - forward security element.

FSO - fire support officer.

g - gram.

gen - generator.

GS - general support.

GSR - ground surveillance radar.

G/VLLD - ground/vehicle laser locator designator.

hasty smoke - characterized by minimal planning; used for short periods to counter enemy action or anticipated enemy action of concern to the commander.

haze - a light concentration of obscuration that restricts accurate enemy observation from the air and ground. This prevents accurate enemy target acquisition, but does not disrupt friendly operations that require limited visibility, such as river crossings. A smoke haze allows limited visibility that reduces the recognition of personnel and equipment from 50 to 150 meters.

HC - a pyrotechnic smoke-producing composition of hexachloroethane, zinc oxide, and aluminum powder employed in certain smoke munitions; has a sharp, acid odor; toxic if released in sufficient quantities in enclosed places; the smoke is cool burning when contrasted to white phosphorus.

HE - high explosive.

HMMWV - high-mobility multipurpose wheeled vehicle.

head wind - wind blowing away from the smoke objective and directly toward the smoke source.

HUMINT - human intelligence.

ICM - improved conventional munition.

IFV - infantry fighting vehicle.

IMINT - imagery intelligence.

individual streamer - the initial phase of a smoke cloud, before the streamers from the point sources merge.

inversion - an increase of air temperature with increase in height (the ground being colder than the surrounding air); this condition usually occurs on clear or partially clear nights and early mornings until about one hour after sunrise, but sometimes persists longer. When stable conditions exist, there are no convection currents and, with wind speeds below 5 knots, little mechanical turbulence. Therefore, stable conditions are the most favorable for ground-released smoke.

IPB - intelligence preparation of the battlefield.

IPE - individual protective equipment.

ir - infrared.

ITV - integrated TOW vehicle.

k - knot(s)

km- kilometer(s).

kmph - kilometer(s) per hour.

LAMPSS - large-area mobile projected smoke system.

lapse - a marked decrease of air temperature with increasing altitude (the ground being warmer than the surrounding air). During unstable or lapse conditions, strong convection currents are found. For smoke operations, the state is defined as unstable. This condition is normally the most unfavorable for the release of smoke.

LC - line of crossing.

LD - line of departure.

LIC - low-intensity conflict.

LOGPAC - logistics package.

LRP - logistics release point.

LTOE - living table of organization and equipment.

m - meter(s).

marking smoke - smoke employed to relay prearranged communications on the battlefield. Frequently used to identify targets, evacuation points, and friendly unit perimeters.

MBA - main battle area.

mech - mechanized.

METT-T - mission, enemy, terrain, troops, and time available.

mid-infrared - electromagnetic energy with wavelength in the range of 3 to 8 micrometers.

min - minute(s).

mm - millimeter(s).

MOGAS - motor gasoline.

MOUT - military operations on urbanized terrain.

MRB - motorized rifle battalion.

MRC - motorized rifle company.

MSR - main supply route.

MTOE - modified table of organization and equipment.

multispectral obscurant - an obscurant that blocks or attenuates more than two portions of the electromagnetic spectrum (such as visual, infrared, and millimeter wave).

NAI - named areas of interest.

NBC - nuclear, biological, and chemical.

NBCC - nuclear, biological, and chemical center.

NCO - noncommissioned officer.

near infrared - electromagnetic energy with wavelengths of 0.7 to 3 micrometers

neutral - a meteorological condition that exists when conditions are intermediate between lapse and inversion; neutral conditions tending toward lapse favor production of smoke curtains; neutral conditions tending toward inversion favor smoke blankets or hazes.

night-vision device - a viewer enabling an operator to see in the dark; also called night-observation device.

NFL - no fire line.

NTC - National Training Center.

OB - order of battle.

obj - objective.

obscurant - chemical agent that decreases the level of energy available for the functions of seekers, trackers, and vision-enhancement devices.

obscuration smoke - smoke placed on or near enemy positions to minimize enemy observation both within and beyond the position area.

oil smoke - see fog oil.

OP - observation point.

OPCON - operational control.

operational continuum - the strategic environment within each theater, consisting of a variety of political, military, and economic conditions and a range of threats that result in a wide range of operations conducted within a continuum; consists of three general states: peacetime competition, conflict, and war.

OPLAN - operation plan.

OPORD - operation order.

OPSEC - operations security.

PD - proximity detonator.

phases of smoke - see individual streamer, build-up phase, uniform phase, and terminal phase.

PHOTINT - photographic intelligence.

PIR - priority intelligence requirement.

PL - phase line.

plt - platoon.

POL - petroleum, oils, and lubricants.

protection smoke - smoke produced to defeat or degrade target acquisition or guidance systems or the effects of directed-energy weapons.

PWP - plasticized white phosphorus.

quartering wind - a wind that blows between tail and flank winds, toward the smoke objective.

RAG - Regimental Artillery Group.

rd - round.

recon - reconnaissance.

red phosphorus - a form of phosphorus not spontaneously flammable.

RFL - restrictive fire line.

RISTA - reconnaissance, intelligence, surveillance, and target acquisition.

RP - red phosphorus.

RPV - remotely piloted vehicle.

RSTA - reconnaissance, surveillance, and target acquisition.

S1 - adjutant.

S2 - intelligence officer.

S3 - operations officer.

S4 - logistics officer.

screening smoke - smoke employed in areas of friendly operation or in areas between friendly and enemy forces to degrade enemy ground and aerial observation; used to conceal ground maneuver, breaching, and recovery operations, as well as key assembly areas, supply routes, and logistic facilities.

selected area - as used in this manual, an area to be concealed by smoke.

SG - smoke generator.

SGF2 - smoke generator fog number 2; also called fog oil.

signature - the visible or audible effects produced when firing a weapon or operating a piece of equipment, such as noise, smoke, flame, heat, or debris; also, an electronic emission subject to detection and traceable to the equipment producing it.

silhouette - the outline or general shape of something contrasted against a lighter background.

SLAR - side-looking airborne radar.

smoke - a particulate of solid or liquid, part of low-vapor pressure that settles out slowly under gravity; in general, smoke particles range downward from about 5 micrometers in diameter to less than 0.1 micrometer in diameter; also means the suspension of small liquid or solid particles in air; the filling for smoke munitions, such as bombs, shells, and grenades; to produce signaling or screening smoke with any munition; generally, any artificial aerosol.

smoke blanket - a dense concentration of smoke established over and around friendly areas to protect them from visual observation from the air and visual precision bombing attack, or established over an enemy area to protect attacking aircraft from air defense fire. Blankets can also be used at night to prevent enemy-observed air attack by flare light. A smoke blanket reduces visual

recognition of personnel and equipment to less than 50 meters.

smoke control officer — the officer designated by the maneuver unit commander to coordinate and control the smoke operation.

smoke curtain — a vertical development of smoke that reduces the enemy's ability to clearly see what is occurring on the other side of the cloud; visual recognition depends on the curtain width and smoke density.

smoke generator — a mechanical device that vaporizes fog oil and releases it to condense in the air as a white smoke.

smoke haze — a light concentration of smoke placed over friendly installations to restrict accurate enemy observation and fire, but not dense enough to hamper friendly operations; density of haze is equivalent to that of light fog.

smoke munition — a device that is either discharged from a weapon or thrown and that makes smoke.

smoke point source — the point from which a smoke munition or smoke device generates an individual streamer of smoke.

smoke position — location of a smoke pot or mechanical smoke generator.

smoke pot — an expendable bucket- or pot-like ammunition that produces a dense smoke by burning a smoke mixture.

smoke projectile — any projectile containing a smoke-producing agent that is released on impact or upon bursting; also called smoke shell.

smoke shell — see smoke projectile.

smoke target analysis — the process of selecting the optimal smoke delivery system to attack specific EO systems.

smoke target development — the

process of situation development and intelligence preparations of the battlefield.

SOP — standing operating procedure.

sophisticated weapons — precision-guided munitions, equipped with infrared, electro-optical, or laser seekers/trackers with or without command links; munitions with high accuracy and, hence, high probability of kill against a target.

special smoke — an obscurant that blocks or attenuates a specific portion of the electromagnetic spectrum (such as visual, infrared, and millimeter wave).

spt — support.

sqd — squad.

stable — see inversion.

streamer — the smoke cloud formed by a single smoke source.

synchronization — the coordination of activities in time, space, and purpose to achieve maximum combat power at the decisive point.

TAA — tactical assembly area.

TAACOM — theater Army area command.

TAC — Tactical Air Command.

TAI — target areas of interest.

tail wind — a wind that blows toward the smoke objective from behind the smoke source.

temperature gradient — comparison of the air temperature at .5 meters above the ground with the air temperature at 4 meters above ground; see also inversion, neutral, and lapse.

terminal phase — that stage of a smoke cloud when the cloud has thinned out and the cover is no longer effective; see also smoke blanket.

thermal infrared — electromagnetic energy with a wavelength range of 3 to 20 micrometers.

TOC — tactical operations center.

TOE — table of organization and equipment.

TOW — tube-launched, optically tracked, wire-guided.

TPU — tank and pump unit.

TVA — target value analysis.

uniform phase — phase of smoke during which the uniformly obscuring cloud exists — the streamers have joined and breakup of the cloud has not begun.

unstable — see lapse.

UTM — universal transverse mercator.

VEESS — vehicle engine exhaust smoke system.

visibility — the distance at which it is possible to distinguish a prominent object against the background with the unaided eye.

visibility criteria — the unit commander's requirement for minimum visibility in a smoke cloud. For example, in obstacle emplacement by engineers, the maneuver brigade commander may want to conceal the engineer operation without hindering their work. He establishes a visibility criteria (such as 150 meters) for the smoke.

visible spectrum — the portion of the electromagnetic spectrum lying between 0.4 and 0.7 micrometers.

white phosphorus — a spontaneously flammable solid that burns to form solid smoke particles of phosphorus pentoxide; the phosphorus pentoxide then reacts with moisture in the atmosphere to form droplets of phosphoric acid; the dilution depends on the relative humidity.

WP — white phosphorus.

## References

New reference material is being published all the time. Present references, as listed below, may become obsolete. To keep up to date, see DA Pam 25-30 (on microfiche).

### Required Publications

Required publications are sources users must read to understand or comply with this publication.

#### Field Manuals (FMs)

3-6, Field Behavior of NBC Agents (Including Smoke and Incendiaries)  
100-5, Operations  
101-5, Staff Organization and Operations

### Related Publications

Related publications are sources of additional information. They are not required to understand this publication.

#### Army Regulations (ARs)

310-25, Dictionary of United States Army Terms  
310-50, Authorized Abbreviations and Brevity Codes

#### Field Manuals (FMs)

3-100, NBC Operations

3-101, Chemical Staffs and Units  
6-20, Fire Support in the AirLand Battle  
17-95, Cavalry Operations  
25-100, Training the Force  
34-1, Intelligence and Electronic Warfare Operations  
71-3, Armored and Mechanized Infantry Brigade  
71-101, Infantry, Airborne, and Air Assault Division Operations (HTF)  
100-2-1, Soviet Army Operations and Tactics  
100-2-2, Soviet Army Specialized Warfare and Rear Area Support  
100-2-3, The Soviet Army Troops Organization and Equipment  
101-5-1, Operational Terms and Symbols

#### Soldier Training Publications (STPs)

3-54B1-SM, Soldier's Manual, MOS 54B, Chemical Operations Specialist, Skill Level 1  
3-54B2-SM, Soldier's Manual, MOS 54B, Chemical Operations Specialist, Skill Level 2  
3-54B34-SM-TG, Soldier's Manual, Skill Levels 3/4 and Trainer's Guide, MOS 54B, Chemical Operations Specialist

# Index

- A**
- Applications  
See Obscuring, screening, protecting, marking.
- Artillery smoke  
See Smoke sustainment, Ammunition consumption.
- B**
- Battlefield, 11.  
Close operations, 12.  
Deep operations, 11.  
Rear operations, 12.
- Battlefield applications  
Obscuring, 13  
Screening, 13  
Protecting, 13  
Marking, 13
- Blanket  
See Screening smoke.
- Breakout from encirclement, 45.
- Building effects  
See Terrain effects, Obstructions.
- By-product smoke  
See Obscurants, how they work, By-product.
- C**
- Chemical battalion  
See Command and control headquarters.
- Chemical brigade  
See Command and control headquarters.
- Chemical staff officer responsibilities, 17.
- Chemical unit task organizations, 84.
- Cloud cover  
See Weather effects.
- Command and control headquarters  
Chemical battalion, 83.  
Chemical brigade, 83.
- Conditions, special, 46.  
Deserts, 49.  
Jungles, 46.  
Mountains, 46.  
NBC conditions, 50.  
Urban terrain, 47.  
Winter zones, 49.
- Countermeasures, US  
See Threat, US countermeasures.
- curtain  
See Screening smoke.
- D**
- Darkness  
See Obscurants, how they work.
- Deception, 50.
- Deliberate smoke operations, 7.
- Delivery systems, 14.  
Armored vehicle grenade launchers, 14.  
Generated smoke, 14.  
Generators, 14.  
Mobile smoke, 14.  
Projected smoke, 14.  
Self-defense smoke, 14.  
Smoke pots and hand grenades, 14.  
Stationary smoke, 15.  
VEESS, vehicle engine exhaust smoke system, 14.  
Weather and terrain effects, 15.
- Delivery, means of  
Aircraft-delivered smoke, 79.  
Armored vehicle grenade launchers, 81.  
Artillery munitions, 78.  
Generators, 81.  
Mortar munitions, 78.  
Rifle grenades, 79.  
Rockets, 79.  
Smoke pots and smoke hand grenades, 80.  
Vehicle engine exhaust systems, 81.
- Description of smoke and obscurants, 6.
- Desert effects, 49
- Dust  
See Obscurants, how they work.
- E**
- Electro-optical systems, 72.  
Command-guided missiles, 74.  
Directed-energy weapons, 76.  
Electromagnetic pulses, 77.  
High-power microwaves, 76.  
Lasers, 76.  
Millimeter wave sensors, 75.
- Obscurant effects, 73.  
Particle beams, 76.  
Radar wave sensors, 75.  
Sensors and effects, 72.  
Sensors and viewers, 73.  
Terminal homing missiles, 75.  
Thermal viewers, 74.
- F**
- Fog  
See Obscurants, how they work.
- Fog oil consumption  
See Smoke sustainment, Fuel consumption.
- G**
- Guide, smoke pot spacing  
See Smoke sustainment.
- H**
- Hasty smoke operations, 7.
- Haze  
See Screening smoke.
- HC smoke  
See Obscurants, how they work.
- Hill masses effects  
See Terrain effects.
- Historical perspective, 5.
- How and where to use smoke, 6.  
See also Uses of smoke and obscurants.
- Humidity  
See Weather effects.
- J**
- Jungle effects, 46
- L**
- Linkup operations, 44.
- M**
- Marking smoke, 13.  
MOGAS consumption  
See Smoke sustainment, Fuel consumption.
- Mortar smoke  
See Smoke sustainment, Ammunition consumption.
- Mountains effects  
See Terrain effects.



## O

Obscurants, how they work, 92.  
Artificial Obscurants, 96.  
Bispectral obscurants, 97.  
By-product obscurants, 94.  
By-product smoke, 94.  
Characteristics, 92.  
Darkness, 93.  
Dust, 94.  
Fog, 93.  
HC smoke, 96.  
Multispectral obscurants, 97.  
Natural obscurants, 93.  
Oil smoke, 96.  
Precipitation, 93.  
Phosphorous smoke, 96.  
Special obscurants, 97.  
Visual smoke, 96.  
Obscuring smoke, 13.  
Obstacle breaching, 46.  
Obstructions  
See Terrain effects.  
Oil smoke  
See Obscurants, how they work.  
Operational concept  
Command and staff considerations, 10.  
Operational level of war, 10.  
See also Operations.  
Tactical level of war, 10.  
Operational continuum, 10.  
Conflict, 10.  
Peacetime, 10.  
War, 11.  
Operations  
Defensive, 36.  
Defensive tactics, 37.  
Offensive phases, 29.  
Offensive tactics, 28.  
Operational concept, 9.  
See also Battlefield.  
See also Hasty and deliberate.

## P

Passage of lines, 44.  
Phosphorous smoke  
See Obscurants, how they work.  
Planning, 7.  
Basic load, 52.  
Estimate preparation, 8.  
Fire support, 53.  
Fog oil resupply, 52.  
Logistics, 52.  
Maintenance, 52.  
Personnel sustainment, 53.

Security, 53.  
Situation and target development, 8.  
Smoke estimate format, 55, 57.  
Smoke mission coordination checklist, 56.  
Smoke target list work sheet, 55, 59.  
Supplies, 52.  
Support plan development, 8.  
Support plan execution, 9.  
Supporting units, 52.  
Sustainment, 51.  
Target analysis, 55.  
See also Smoke sustainment.  
Precipitation  
See Obscurants, how they work.  
See also Weather effects.  
Protecting smoke, 13.

## R

Reconnaissance, surveillance, and target acquisition, 18.  
Aerial recon, 19.  
Ground recon, 19.  
Artillery recon, 20.  
Relief in place, 43.  
Retrograde, 42.  
Delay, 43.  
Retirement, 43.  
Withdrawal, 43.  
River crossings, 45.

## S

Safety, 82.  
Sandstorms  
See Obscurants, how they work.  
Screening smoke, 13.  
Smoke blanket, 13.  
Smoke curtain, 13.  
Smoke haze, 13.  
Slope and valley effects  
See Terrain effects.  
Smoke and obscurants,  
Categories of, 7.  
Smoke Capabilities, 85.  
Smoke estimate  
Preparation, 8.  
Format, 55.  
Smoke generator units, 83.  
Smoke organizations, 83.  
Smoke sustainment, 86.  
Ammunition consumption, 88.  
Fuel consumption, 87.  
Smoke pot consumption, 86.  
Smoke pot consumption guide, 86.  
Smoke pot spacing guide, 86.

Smoke units, 15.  
Chemical staff officer's responsibilities, 17.  
See also Smoke organizations.  
Command and support, 16.  
Commander's responsibilities, 17.  
Organization and principles, 16.  
Responsibilities, 17.  
Tactics, techniques, and procedures, 15.  
Unit guidelines, 16.  
Special conditions  
See Conditions, special.  
Spectrum of conflict, 11.

## T

Tactics, defensive  
See Operations.  
Target analysis  
Situation & target development, 8.  
Procedures, 55.  
Target list, 55.  
Terrain effects, 90.  
Flat, unbroken and over water, 90.  
Large hill masses and mountains, 91.  
Obstructions, 91.  
Slopes and valleys, 91.  
Threat, 18.  
Aerial recon, 19.  
Artillery recon, 20.  
Defensive smoke, 22.  
Ground recon, 19.  
Offensive smoke use, 21.  
Smoke tactics, 20.  
US countermeasures to Threat smoke use, 25.

## U

Urban effects, 47  
Uses of smoke and obscurants, 6.  
See also How and where to use smoke.

## W

Weather effects, 89.  
Cloud cover, 90.  
Humidity, 90.  
Precipitation, 90.  
Temperature gradients, 89.  
Wind, 89.  
See also Terrain effects, Large hill masses and mountains, Slopes & valleys.  
Winter zones, 49

**FM 3-50**

4 December 1990

By Order of the Secretary of the Army:

**CARL E. VUONO**  
General, United States Army  
Chief of Staff

Official:

**THOMAS F. SIKORA**  
Brigadier General, United States Army  
The Adjutant General

**Distribution:**

Active Army, USAR, and ARNG: To be distributed in accordance with DA Form 12-11E-R, requirements for FM 3-50, Smoke Operations (Qty rqr block no. 743.